

A1B15EN2

Topics

- Electrical parameters of power lines and ES elements
- DC and AC power lines LV, MV
- HV power lines, substitution elements
- Meshed grids
- Electrical waves on power lines
- Short-circuits
- Ground faults
- Transmission stability
- Electrical protections
- Substations
- Grounding
- Dimensioning

References

- [1] www.powerwiki.cz
- [2] Blume, Steven Warren. Electric power system basics: for the nonelectrical professional [online]. Hoboken: Wiley, 2007 [cit. 2013-02-08]. Dostupné z: <<http://onlinelibrary.wiley.com/book/10.1002/9780470185810>>. ISBN 978-0-470-18581-0.
- [3] El-Hawary, M. E. Introduction to electrical power systems [online]. New York: Wiley, 2008. IEEE Press series on power engineering [cit. 2013-02-08]. Dostupné z: <<http://onlinelibrary.wiley.com/book/10.1002/9780470411377>>. ISBN 978-0-470-41137-7.
- [4] Hase, Yoshihide. Handbook of power system engineering. Chichester: Wiley, ©2007. xxvi, 548 s. ISBN 9780470033678.
- [5] Saccomanno, Fabio. Electric power systems: analysis and control. Hoboken: Wiley, ©2003. xiii, 730 s. ISBN 0-471-23439-7.

- [6] Kasicki, Ismail. Analysis and design of low-voltage power systems: an engineer's field guide. Weinheim: Wiley, ©2002. xxii, 387 s. ISBN 9783527602339.
- [7] Kasikci, Ismail. Short circuits in power systems: a practical guide to IEC 60909. Weinheim: Wiley, ©2002. xvi, 262 s. ISBN 9783527600465.
- [8] Horowitz, Stanley H. a Arun G. Phadke. Power system relaying. 3rd ed. Chichester: Wiley, ©2008. xvi, 331 s. ISBN 9780470758786.

Overhead Power line Electrical Parameters

4 basic (primary) el. parameters (for each phase)

- Resistance R_1 (Ω/km)
- Operational inductance L_1 (H/km)
- Conductance G_1 (S/km)
- Operational capacity C_1 (F/km)

Secondary parameters

- inductive reactance
 $X_1 = \omega L_1 = 2\pi f L_1$ (Ω / km)
- susceptance
 $B_1 = \omega C_1 = 2\pi f C_1$ (S/km)
- longitudinal impedance
 $\hat{Z}_{11} = R_1 + jX_1$ (Ω / km)

- cross admittance

$$\hat{Y}_{q1} = G_1 + jB_1 \quad (\text{S/km})$$

- wave impedance

$$\hat{Z}_v = \sqrt{\frac{\hat{Z}_{11}}{\hat{Y}_{q1}}} \quad (\Omega)$$

- propagation constant

$$\hat{\gamma} = \sqrt{\hat{Z}_{11} \hat{Y}_{q1}} = \alpha + j\beta \quad (\text{km}^{-1})$$

α – specific damping

β – specific phase shift

Note:

- we consider symmetrical supply and load
- networks
 - LV – mainly R
 - MV – R, L (in failures C)
 - HV – R, L, G, C (distributed)

Overhead power line conductors

- full cross section or twist (1 or more materials)
- ropes Cu, Al, alloys, composites, optical wires, high-temperature materials
- ACSR (Aluminum Conductor Steel Reinforced) = carrying Fe core + conductive Al coat

$$S \in (180 ; 680) \text{ mm}^2$$

- example of labeling
 - 382-AL1/49-ST1A
 - 350AlFe4
 - AlFe450/52

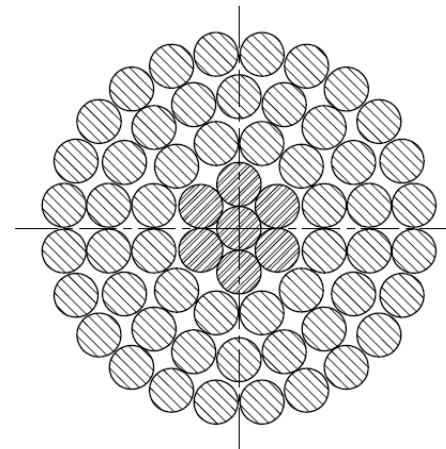

Rope	Construction	Fe				Al			Rope		
		Nb. of wires	Diameter of wire	Diameter of inner tube	Cross-section	Nb. Of wires	Diameter of wire	Cross-section	Diameter	Cross-section	R_{DC+20}
		ks	mm	mm	mm ²	ks	mm	mm ²	mm	mm ²	$\Omega \cdot \text{km}^{-1}$
350 AlFe 4	1+6+12/12+18	19	2,36	11,80	83,11	30	3,75	331,34	26,80	414,45	0,087
450 AlFe 8	3+9/18+14+20	12	2,36	9,90	52,49	18+34	1,90+3,75	426,55	28,70	479,05	0,0674
AlFe 450/52	3+9/12+18+24	12	2,36	9,81	52,49	54	3,25	447,97	29,31	500,46	0,0646
382-AL1/49-ST1A	1+6/12+18+24	7	3,00	3,00	49,48	54	3,00	381,70	27,00	431,18	0,0758
476-AL1/62-ST1A	1+6/12+18+24	7	3,35	10,05	61,70	54	3,35	475,96	30,15	537,66	0,0608

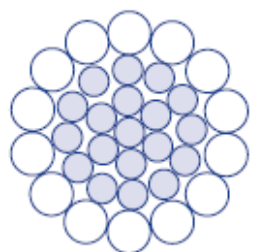

14Al/19Fe

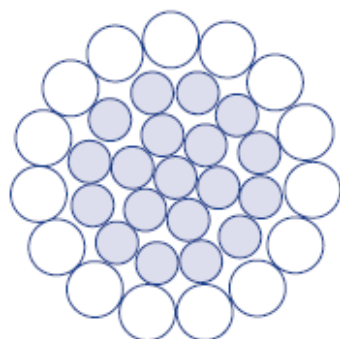

15Al/19Fe

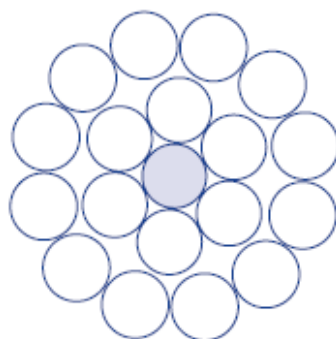

18Al/1Fe

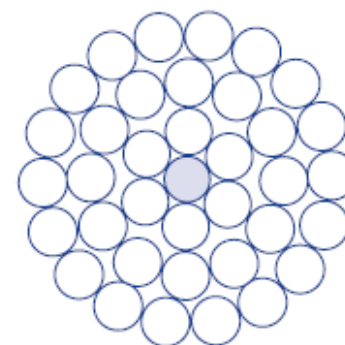

36Al/1Fe

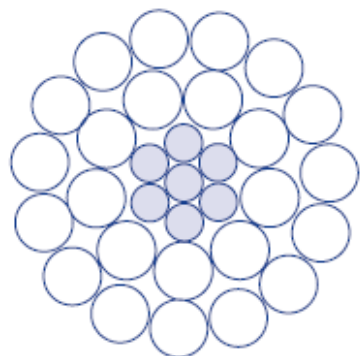

24Al/7Fe

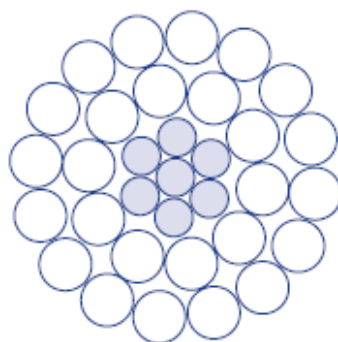

26Al/7Fe

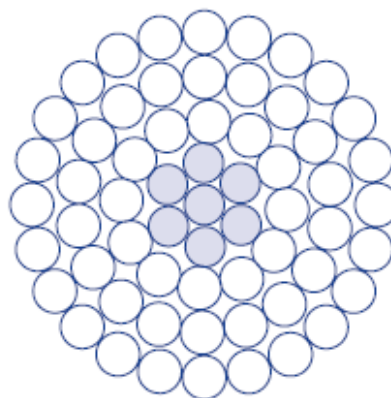

54Al/7Fe

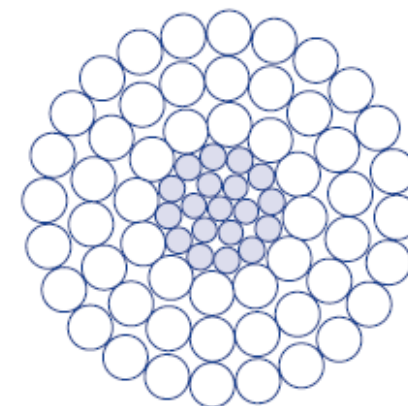

54Al/19Fe



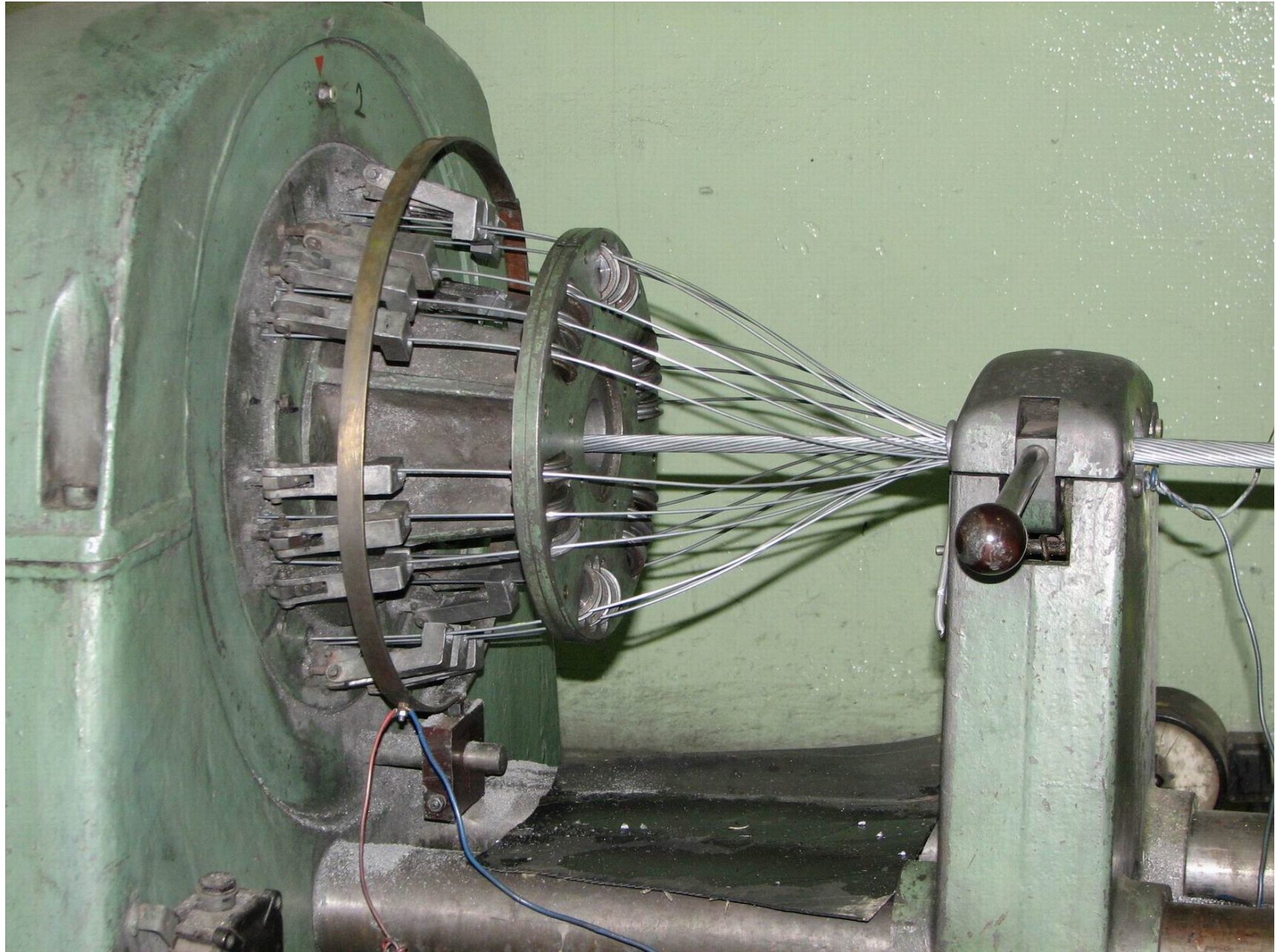

Resistance

Value influenced by:

conductor material, temperature, skin effect, elongation due to twisted wires, current density distribution along stripes, sag, unequal cross section, connections

With DC current (at 20°C)

$$R_{1dc0} = \frac{\rho_0}{S} \quad (\Omega / \text{km})$$

$$\text{Cu: } \rho_0 = 1,78 \cdot 10^{-8} \quad (\Omega\text{m})$$

$$\text{Al: } \rho_0 = 2,81 \cdot 10^{-8} \quad (\Omega\text{m})$$

$$\text{Fe: } \rho_0 = 12,8 \cdot 10^{-8} \quad (\Omega\text{m})$$

$$\rho_{\text{AlFeDC}} = \frac{\rho_{\text{Al}} \cdot S_{\text{Al}} + \rho_{\text{Fe}} \cdot S_{\text{Fe}}}{S_{\text{Al}} + S_{\text{Fe}}}$$

Temperature effect

$$k_T = 1 + \alpha(T_1 - T_0) + \beta(T_1 - T_0)^2 \quad (-)$$

$$\text{Cu: } \alpha = 3,93 \cdot 10^{-3} \quad (\text{K}^{-1})$$

$$\text{Al: } \alpha = 4,03 \cdot 10^{-3} \quad (\text{K}^{-1})$$

$$\text{Fe: } \alpha = 4,5 \cdot 10^{-3} \quad (\text{K}^{-1})$$

$$\beta \approx 10^{-6} \text{ K}^{-2} \rightarrow \text{under normal } \Delta T \text{ neglected}$$

$$\alpha = \frac{\alpha_{\text{Al}} \cdot \alpha_{\text{Fe}} \left(\frac{\rho_{\text{Al}}}{S_{\text{Al}}} + \frac{\rho_{\text{Fe}}}{S_{\text{Fe}}} \right) + \alpha_{\text{Al}} \cdot \frac{\rho_{\text{Fe}}}{S_{\text{Fe}}} + \alpha_{\text{Fe}} \cdot \frac{\rho_{\text{Al}}}{S_{\text{Al}}}}{\frac{\rho_{\text{Al}}}{S_{\text{Al}}} + \frac{\rho_{\text{Fe}}}{S_{\text{Fe}}} + \alpha_{\text{Al}} \cdot \frac{\rho_{\text{Al}}}{S_{\text{Al}}} + \alpha_{\text{Fe}} \cdot \frac{\rho_{\text{Fe}}}{S_{\text{Fe}}}}$$

Influence of AC current, e.g.

$$k_{\text{ac}} = 1 + 0,0375 \cdot 10^{-12} \cdot \left[\frac{(r_2 - r_1) \cdot f}{r_2 \cdot R_{\text{dc0}}} \right]^2 \quad (-; \text{m, m, Hz, m, } \Omega \cdot \text{m}^{-1})$$

$$k_{ac} = 1,004 \div 1,3 \quad (-)$$

Empirically by the number of layers Al (Fe core 2÷3% of current)

$$\text{two layers} \quad k_{ac} = 1,04$$

$$\text{three layers} \quad k_{ac} = 1,06$$

$$\text{four layers} \quad k_{ac} = 1,05$$

In catalogue usually R_{1dc0}

$$\Rightarrow R_1 = R_{1dc0} \cdot k_T \cdot k_{ac} \quad (\Omega / \text{km})$$

$$\text{cca } R_{1dc0} \in (0,05 ; 2) \Omega / \text{km}$$

$$\text{AlFe42} \quad R_{1dc0} \sim 0,7 \Omega / \text{km}$$

$$\text{AlFe70} \quad R_{1dc0} \sim 0,4 \Omega / \text{km}$$

$$\text{AlFe95} \quad R_{1dc0} \sim 0,3 \Omega / \text{km}$$

$$\text{AlFe120} \quad R_{1dc0} \sim 0,2 \Omega / \text{km}$$

$$\text{AlFe210} \quad R_{1dc0} \sim 0,14 \Omega / \text{km}$$

$$\text{AlFe350} \quad R_{1dc0} \sim 0,09 \Omega / \text{km}$$

$$\text{AlFe450} \quad R_{1dc0} \sim 0,07 \Omega / \text{km}$$

$$\text{AlFe680} \quad R_{1dc0} \sim 0,04 \Omega / \text{km}$$

Inductance and longitudinal impedance

Inductance and impedance in a loop

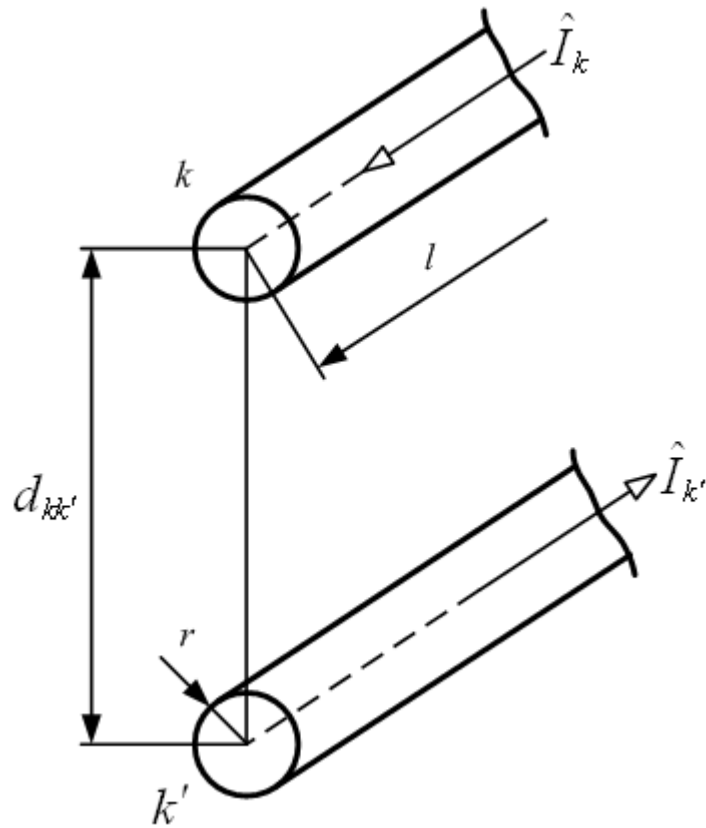

$$r \ll d \ll l \quad d_{kk'} = d \quad \hat{I}_k = -\hat{I}_{k'}$$

Internal inductance of a conductor (magnetic flux inside the conductor)

$$L_{ik} = \frac{\mu_0 \mu_{rv}}{8\pi} \alpha \quad (\text{H/m; H/m, -, -})$$

$$\mu_0 = 4\pi \cdot 10^{-7} \text{ H} \cdot \text{m}^{-1}$$

μ_{rv}relative permeability of conductor

αinequality of current distribution through cross-section

External inductance of a conductor in a loop (magnetic flux outside the conductor)

$$L_{ek} = \frac{\mu_0}{2\pi} \ln \frac{d}{r} \quad (\text{H/m; H/m, m, m})$$

Self-inductance

$$L_v = L_{ik} + L_{ek} = \frac{\mu_0 \mu_{rv}}{8\pi} \alpha + \frac{\mu_0}{2\pi} \ln \frac{d}{r}$$

$$L_v = 0,05 \mu_{rv} \alpha + 0,46 \log \frac{d}{r} = 0,46 \log \frac{d}{\xi r} \quad (\text{mH} \cdot \text{km}^{-1}; \text{m, m})$$

ξ ... coefficient of current density inequality in cross section and permeability

$$\xi = 10^{\frac{0,05\mu_r\alpha}{0,46}}$$

$\xi \in (0,809 ; 0,826)$ for common ACSR ropes

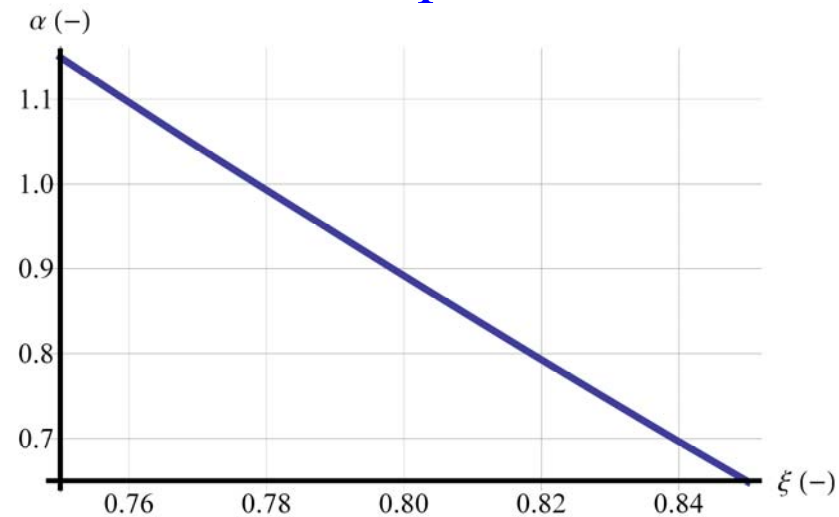

Impedance of one conductor in a loop of two conductors

$$\hat{Z}_{kv} = R_{1k} + j\omega \cdot 0,46 \cdot 10^{-6} \cdot \log \frac{d}{\xi r} \quad (\Omega \cdot m^{-1})$$

Self-impedance of a loop conductor-ground

- Ground as a conductor of stationary AC current
- Rüdénberg's conception
- Density of AC current in a ground is unequal, the maximum is under the conductor

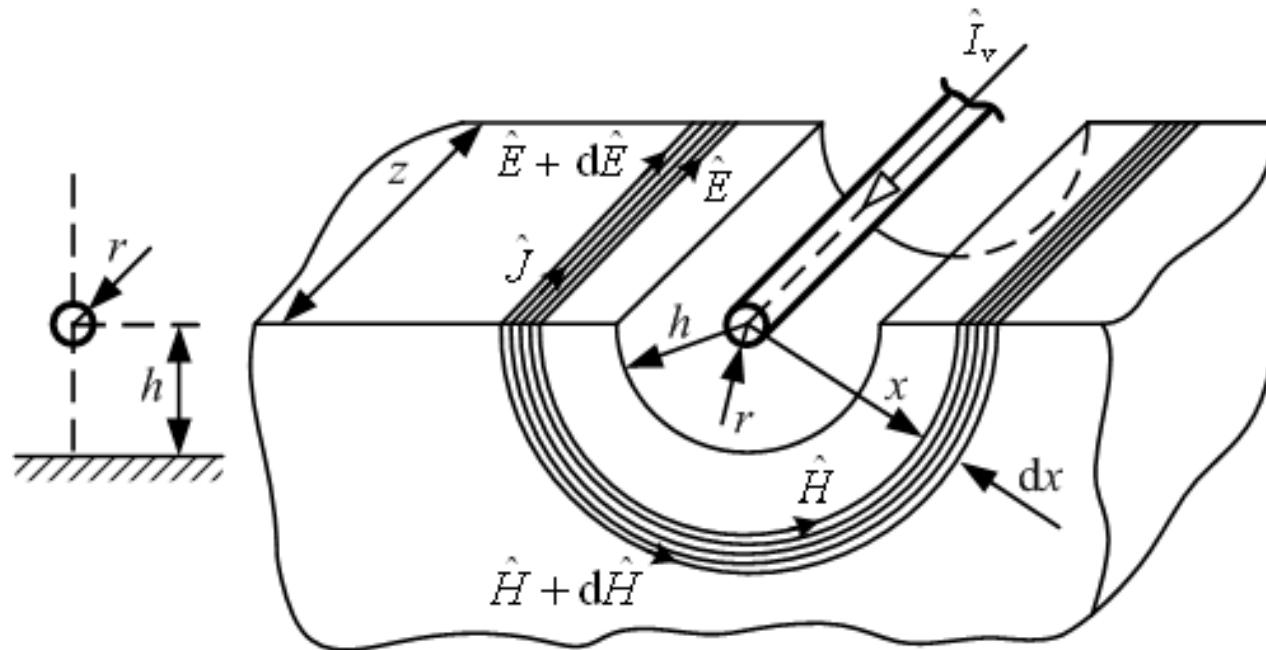

3 components:

- a) R_{1k} – resistance respecting power losses in the conductor
- b) X_{1k} – reactance respecting part of magnetic flux coupled with the conductor and closed in the conductor and in the air
- c) Z_{1g} – impedance respecting part of magnetic flux in the ground coupled with conductor

$$\hat{Z}_{kk} = R_{kk} + jX_{kk} = R_{1k} + jX_{1k} + R_{1g} + jX_{1g}$$

$$R_{1g} = \pi^2 f \cdot 10^{-7} \quad (\Omega \cdot \text{m}^{-1}; \text{Hz})$$

$$\text{for } f = 50 \text{ Hz je } R_{1g} = 0,0495 \Omega \cdot \text{km}^{-1}$$

$$\hat{Z}_{kk} = R_{1k} + \pi^2 f \cdot 10^{-4} + j\omega \cdot 10^{-3} \cdot 0,46 \log \frac{D_g}{\xi \cdot r} \quad (\Omega \cdot \text{km}^{-1})$$

Fictitious conductor deep in the ground which has the same impacts as the real current in the ground

$$D_g = \frac{0,178\sqrt{\rho \cdot 10^7}}{\sqrt{f}} \quad (\text{m; } \Omega\text{m, Hz})$$

$D_g \sim 100\text{x m}$, i.e. $h \ll D_g$
 ρ ...ground resistivity

Type of soil	ρ ($\Omega \cdot \text{m}$)
peat	30
topsoil and clay	100
moist sand	200 - 300
dry gravel and sand	1000 - 3000
stony soil	3000 - 10000

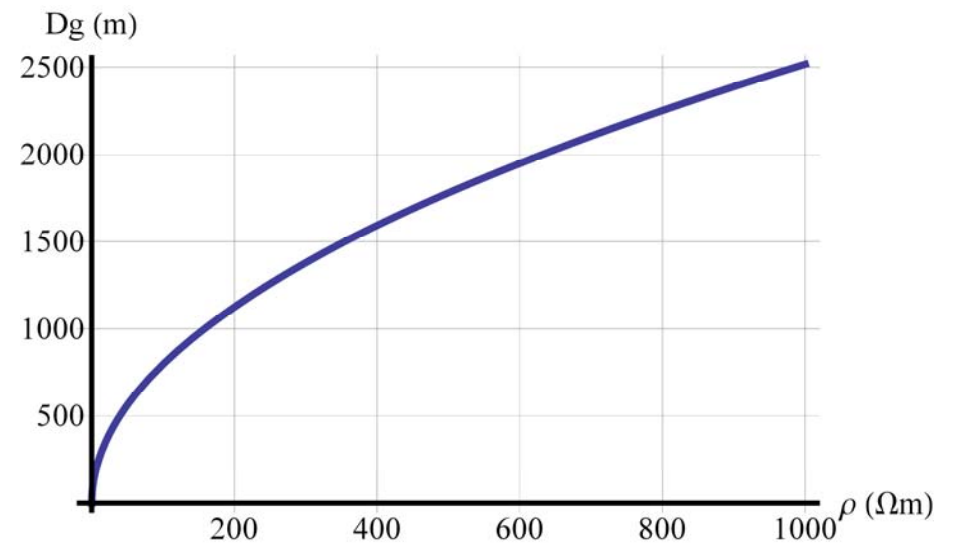

Mutual impedance of two loops conductor-ground

- double wire one-phase power line $d_{km} \leq h$
- return currents are compensated by each other

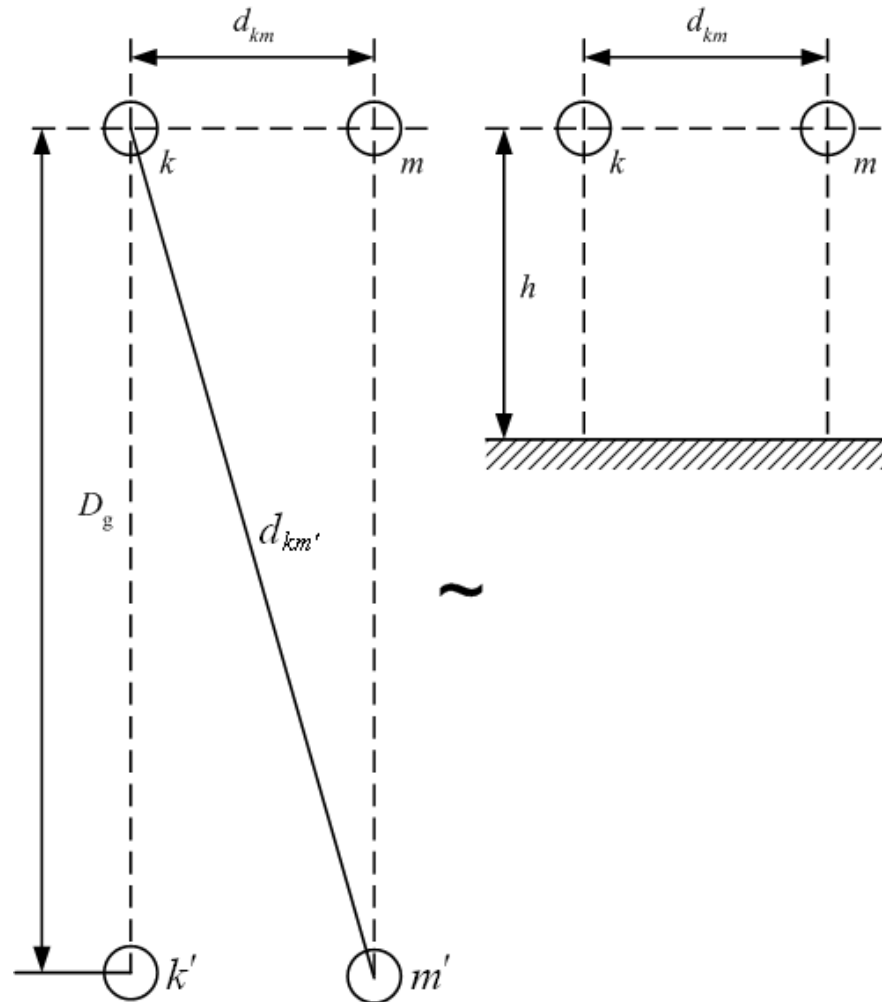

$D_g \gg d_{km} \rightarrow$ resulting electromagnetic impacts of return currents in the conductors k' , m' on the real conductors k , m is almost zero

Impedance of one conductor in a loop

$$\Delta \hat{U}_{kv} = \hat{Z}_{kv} \cdot \hat{I}_k = \hat{Z}_{kk} \cdot \hat{I}_k + \hat{Z}_{km} \cdot \hat{I}_m$$
$$\hat{I}_k = -\hat{I}_m \Rightarrow \hat{Z}_{kv} = \hat{Z}_{kk} - \hat{Z}_{km}$$

Hence after substitutions

$$\hat{Z}_{kk} = R_{1k} + R_{1g} + j\omega \cdot 10^{-3} \cdot 0,46 \log \frac{D_g}{\xi r} \quad (\Omega \cdot \text{km}^{-1})$$

$$\hat{Z}_{kv} = R_{1k} + j\omega \cdot 0,46 \cdot 10^{-3} \cdot \log \frac{d_{km}}{\xi r} \quad (\Omega \cdot \text{km}^{-1})$$

$$\hat{Z}_{km} = \hat{Z}_{kk} - \hat{Z}_{kv} = R_{1g} + j\omega \cdot 10^{-3} \cdot 0,46 \log \frac{D_g}{d_{km}} \quad (\Omega \cdot \text{km}^{-1})$$

Configuration of n real conductors

Configuration of loops n real conductors and the ground is substituted by n real and n fictitious conductors in mutual distance D_g .

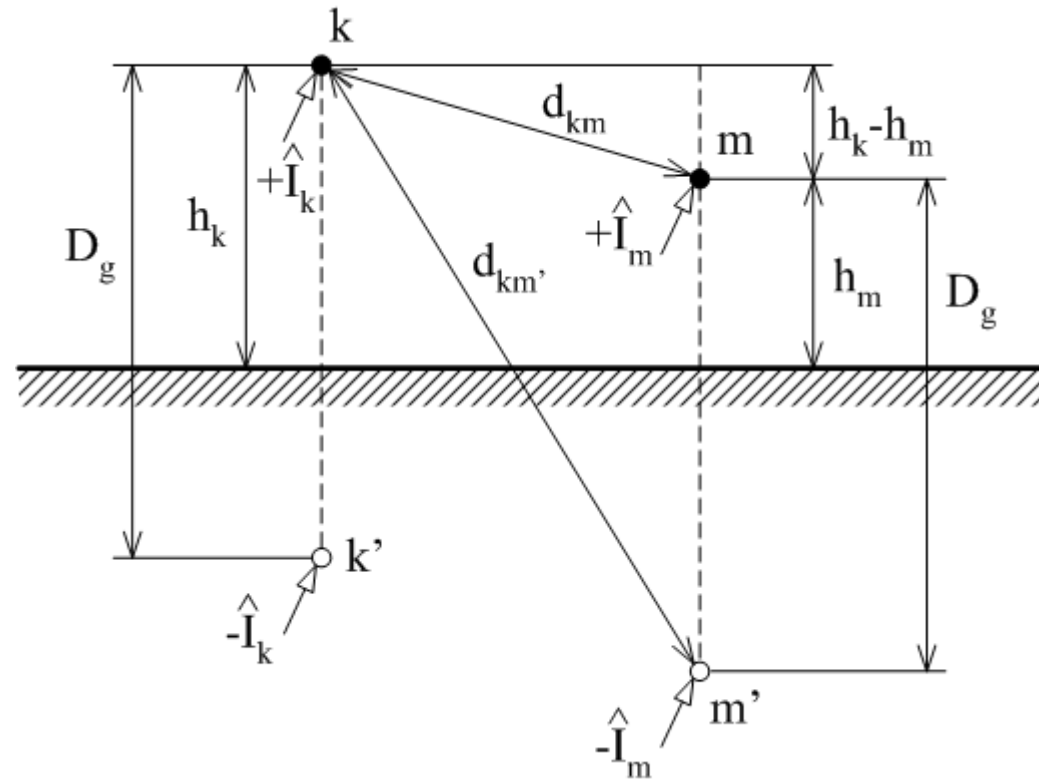

Self-inductance and impedance (loop k-k')

$$M_{kk} = 0,46 \log \frac{D_g}{\xi r_k} \quad (\text{mH / km; m, m})$$

$r_k \dots k^{\text{th}}$ conductor radius

$$\hat{Z}_{kk} = R_{kk} + j\omega L_{kk} = R_{1k} + R_{1g} + j0,1445 \log \frac{D_g}{\xi \cdot r_k} \quad \left(\frac{\Omega}{\text{km}} \right)$$

Mutual inductance and impedance (loop k-k', m-m')

$$M_{km} = 0,46 \log \frac{D_g}{d_{km}} = M_{mk} \quad (\text{mH / km; m, m})$$

$$\hat{Z}_{km} = \hat{Z}_{mk} = R_{km} + j\omega L_{km} = R_{1g} + j0,1445 \log \frac{D_g}{d_{km}} \quad \left(\frac{\Omega}{\text{km}} \right)$$

Voltage drop in k^{th} conductor

$$\Delta \hat{U}_k = \sum_{m=1}^n \hat{Z}_{km} \hat{I}_m \quad (\text{V / km})$$

(for $m = k$ is $d_{kk} = \xi r_k$)

Operational impedance (inductance) – for 1 single conductor, it causes the same voltage drop as in the system of n conductors (it can be a complex number, done by operating condition)

$$\Delta \hat{U}_k = \sum_{m=1}^n \hat{Z}_{km} \hat{I}_m = \hat{Z}_k \hat{I}_k \Rightarrow \hat{Z}_k = \frac{\sum_{m=1}^n \hat{Z}_{km} \hat{I}_m}{\hat{I}_k} \quad \hat{L}_k = \frac{\sum_{m=1}^n M_{km} \hat{I}_m}{\hat{I}_k}$$

n -conductor system

$$[\Delta \hat{U}] = j\omega [M_{km}] [\hat{I}]$$

Simple (unbalanced) three-phase power line

Symmetrical loading

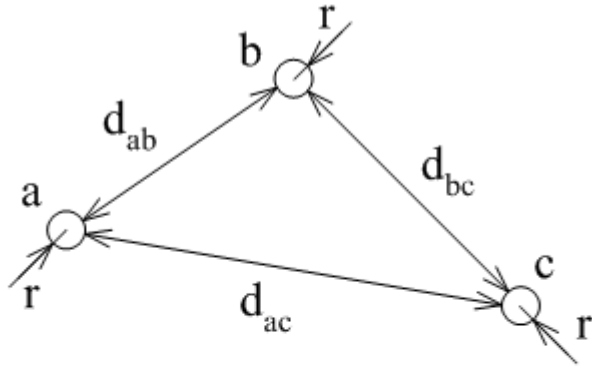

$$\hat{I}_a = \hat{I}_a$$
$$\hat{I}_b = \hat{a}^2 \hat{I}_a$$
$$\hat{I}_c = \hat{a} \hat{I}_a$$

$$\hat{a} = -\frac{1}{2} + j\frac{\sqrt{3}}{2} = e^{+j\frac{2\pi}{3}}$$

$$\hat{a}^2 = -\frac{1}{2} - j\frac{\sqrt{3}}{2} = e^{-j\frac{2\pi}{3}}$$

$$1 + \hat{a}^2 + \hat{a} = 0$$



Operational inductances

$$\hat{L}_a = \frac{M_{aa}\hat{I}_a + M_{ab}\hat{I}_b + M_{ac}\hat{I}_c}{\hat{I}_a} = M_{aa} + \hat{a}^2 M_{ab} + \hat{a} M_{ac}$$

$$\hat{L}_b = \frac{M_{ab}\hat{I}_a + M_{bb}\hat{I}_b + M_{bc}\hat{I}_c}{\hat{I}_b} = \hat{a} M_{ab} + M_{bb} + \hat{a}^2 M_{bc}$$

$$\hat{L}_c = \frac{M_{ac}\hat{I}_a + M_{bc}\hat{I}_b + M_{cc}\hat{I}_c}{\hat{I}_c} = \hat{a}^2 M_{ac} + \hat{a} M_{bc} + M_{cc}$$

Generally

$$M_{aa} = M_{bb} = M_{cc} \quad M_{ab} \neq M_{bc} \neq M_{ac}$$

$$\hat{L}_a \neq \hat{L}_b \neq \hat{L}_c$$

→ unequal voltage drops (magnitude and phase) → voltage unbalance,
active power transfer between phases through electromagnetic coupling
without further sources loading → transposition

Transposition of three-phase power line

= conductors position exchange so that each one is in a definite position for 1/3 length

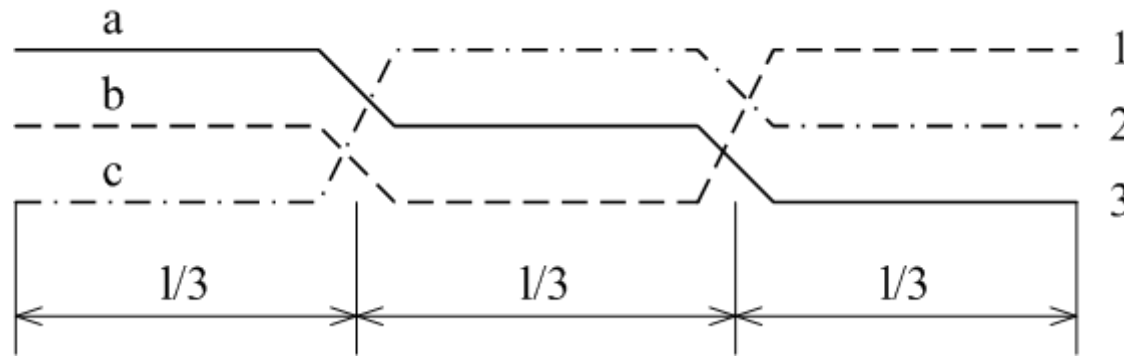

Voltage drops

$$\begin{pmatrix} \Delta \hat{U}_a \\ \Delta \hat{U}_b \\ \Delta \hat{U}_c \end{pmatrix} = \frac{1}{3} j\omega \left\{ \begin{pmatrix} M_{11} & M_{12} & M_{13} \\ M_{12} & M_{22} & M_{23} \\ M_{13} & M_{23} & M_{33} \end{pmatrix} + \begin{pmatrix} M_{33} & M_{13} & M_{23} \\ M_{13} & M_{11} & M_{12} \\ M_{23} & M_{12} & M_{22} \end{pmatrix} + \begin{pmatrix} M_{22} & M_{23} & M_{12} \\ M_{23} & M_{33} & M_{13} \\ M_{12} & M_{13} & M_{11} \end{pmatrix} \right\} \begin{pmatrix} \hat{I}_a \\ \hat{I}_b \\ \hat{I}_c \end{pmatrix}$$

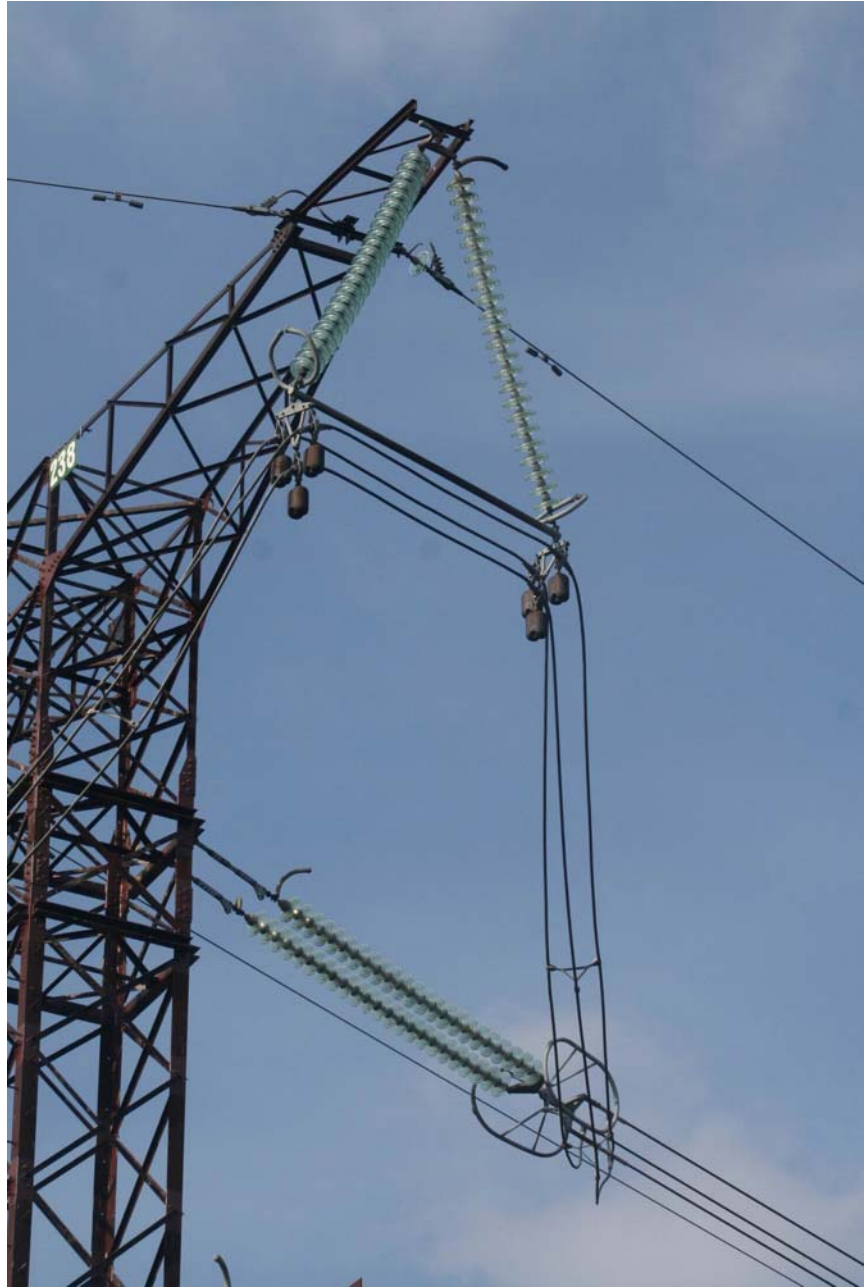

Let's mark

$$M = \frac{1}{3}(M_{11} + M_{22} + M_{33})$$

$$M' = \frac{1}{3}(M_{12} + M_{13} + M_{23})$$

Then

$$\begin{pmatrix} \Delta \hat{U}_a \\ \Delta \hat{U}_b \\ \Delta \hat{U}_c \end{pmatrix} = j\omega \begin{pmatrix} M & M' & M' \\ M' & M & M' \\ M' & M' & M \end{pmatrix} \begin{pmatrix} \hat{I}_a \\ \hat{a}^2 \hat{I}_a \\ \hat{a} \hat{I}_a \end{pmatrix}$$

Phase operational inductances at transposed and symmetrically loaded power line are equal and real:

$$L_a = M + \hat{a}^2 M' + \hat{a} M'$$

$$L_a = L_b = L_c = M - M'$$

After substitution

$$M = 0,46 \log \frac{D_g}{\xi r} \quad (\text{mH / km})$$

$$M' = 0,46 \log \frac{D_g}{d} \quad (\text{mH / km})$$

mean geometrical distance

$$d = \sqrt[3]{d_{12} d_{13} d_{23}}$$

Finally

$$L_1 = L_a = L_b = L_c = 0,46 \log \frac{d}{\xi r} \quad (\text{mH / km})$$

$$\hat{Z}_1 = \hat{Z} - \hat{Z}' = R_1 + j0,1445 \log \frac{d}{\xi \cdot r} \quad \left(\frac{\Omega}{\text{km}} \right)$$

Double power lines with two ground wires

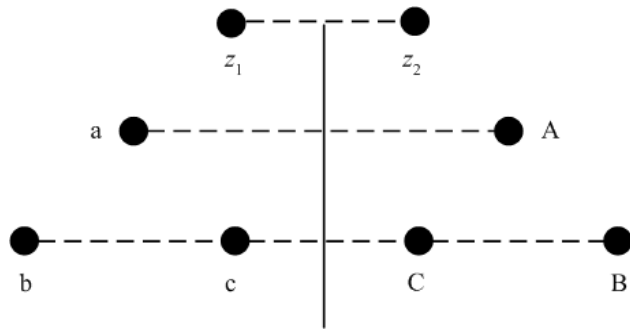

$$\begin{pmatrix} \Delta \hat{U}_a \\ \Delta \hat{U}_b \\ \Delta \hat{U}_c \\ \Delta \hat{U}_A \\ \Delta \hat{U}_B \\ \Delta \hat{U}_C \\ \Delta \hat{U}_{z1} \\ \Delta \hat{U}_{z2} \end{pmatrix} = \begin{pmatrix} \hat{Z}_{aa} & \hat{Z}_{ab} & \hat{Z}_{ac} & \hat{Z}_{aA} & \hat{Z}_{aB} & \hat{Z}_{aC} & \hat{Z}_{az1} & \hat{Z}_{az2} \\ \hat{Z}_{ba} & \hat{Z}_{bb} & \hat{Z}_{bc} & \hat{Z}_{bA} & \hat{Z}_{bB} & \hat{Z}_{bC} & \hat{Z}_{bz1} & \hat{Z}_{bz2} \\ \hat{Z}_{ca} & \hat{Z}_{cb} & \hat{Z}_{cc} & \hat{Z}_{cA} & \hat{Z}_{cB} & \hat{Z}_{cC} & \hat{Z}_{cz1} & \hat{Z}_{cz2} \\ \hat{Z}_{Aa} & \hat{Z}_{Ab} & \hat{Z}_{Ac} & \hat{Z}_{AA} & \hat{Z}_{AB} & \hat{Z}_{AC} & \hat{Z}_{Az1} & \hat{Z}_{Az2} \\ \hat{Z}_{Ba} & \hat{Z}_{Bb} & \hat{Z}_{Bc} & \hat{Z}_{BA} & \hat{Z}_{BB} & \hat{Z}_{BC} & \hat{Z}_{Bz1} & \hat{Z}_{Bz2} \\ \hat{Z}_{Ca} & \hat{Z}_{Cb} & \hat{Z}_{Cc} & \hat{Z}_{CA} & \hat{Z}_{CB} & \hat{Z}_{CC} & \hat{Z}_{Cz1} & \hat{Z}_{Cz2} \\ \hat{Z}_{z1a} & \hat{Z}_{z1b} & \hat{Z}_{z1c} & \hat{Z}_{z1A} & \hat{Z}_{z1B} & \hat{Z}_{z1C} & \hat{Z}_{z1z1} & \hat{Z}_{z1z2} \\ \hat{Z}_{z2a} & \hat{Z}_{z2b} & \hat{Z}_{z2c} & \hat{Z}_{z2A} & \hat{Z}_{z2B} & \hat{Z}_{z2C} & \hat{Z}_{z2z1} & \hat{Z}_{z2z2} \end{pmatrix} \begin{pmatrix} \hat{I}_a \\ \hat{I}_b \\ \hat{I}_c \\ \hat{I}_A \\ \hat{I}_B \\ \hat{I}_C \\ \hat{I}_{z1} \\ \hat{I}_{z2} \end{pmatrix}$$

After modifications it can be written (assumption of continuous grounding of ground wires)

$$\begin{aligned}
(\Delta \hat{U}_v) &= (\hat{Z}_{vv})(\hat{I}_v) + (\hat{Z}_{vV})(\hat{I}_V) + (\hat{Z}_{vz})(\hat{I}_z) \\
(\Delta \hat{U}_V) &= (\hat{Z}_{Vv})(\hat{I}_v) + (\hat{Z}_{VV})(\hat{I}_V) + (\hat{Z}_{Vz})(\hat{I}_z) \\
0 &= (\Delta \hat{U}_z) = (\hat{Z}_{zv})(\hat{I}_v) + (\hat{Z}_{zV})(\hat{I}_V) + (\hat{Z}_{zz})(\hat{I}_z)
\end{aligned}$$

⇒ currents in ground wires

$$\begin{pmatrix} \hat{\mathbf{I}}_z \end{pmatrix} = -\begin{pmatrix} \hat{\mathbf{Z}}_{zz} \end{pmatrix}^{-1} \left[\begin{pmatrix} \hat{\mathbf{Z}}_{zv} \end{pmatrix} \begin{pmatrix} \hat{\mathbf{I}}_v \end{pmatrix} + \begin{pmatrix} \hat{\mathbf{Z}}_{zv} \end{pmatrix} \begin{pmatrix} \hat{\mathbf{I}}_v \end{pmatrix} \right]$$

For modified power line

$$\begin{pmatrix} \Delta \hat{\mathbf{U}}_v \end{pmatrix} = \left[\begin{pmatrix} \hat{\mathbf{Z}}_{vv} \end{pmatrix} - \begin{pmatrix} \hat{\mathbf{Z}}_{vz} \end{pmatrix} \begin{pmatrix} \hat{\mathbf{Z}}_{zz} \end{pmatrix}^{-1} \begin{pmatrix} \hat{\mathbf{Z}}_{zv} \end{pmatrix} \right] \begin{pmatrix} \hat{\mathbf{I}}_v \end{pmatrix} + \left[\begin{pmatrix} \hat{\mathbf{Z}}_{vv} \end{pmatrix} - \begin{pmatrix} \hat{\mathbf{Z}}_{vz} \end{pmatrix} \begin{pmatrix} \hat{\mathbf{Z}}_{zz} \end{pmatrix}^{-1} \begin{pmatrix} \hat{\mathbf{Z}}_{zv} \end{pmatrix} \right] \begin{pmatrix} \hat{\mathbf{I}}_v \end{pmatrix}$$

$$\begin{pmatrix} \Delta \hat{\mathbf{U}}_v \end{pmatrix} = \left[\begin{pmatrix} \hat{\mathbf{Z}}_{vv} \end{pmatrix} - \begin{pmatrix} \hat{\mathbf{Z}}_{vz} \end{pmatrix} \begin{pmatrix} \hat{\mathbf{Z}}_{zz} \end{pmatrix}^{-1} \begin{pmatrix} \hat{\mathbf{Z}}_{zv} \end{pmatrix} \right] \begin{pmatrix} \hat{\mathbf{I}}_v \end{pmatrix} + \left[\begin{pmatrix} \hat{\mathbf{Z}}_{vv} \end{pmatrix} - \begin{pmatrix} \hat{\mathbf{Z}}_{vz} \end{pmatrix} \begin{pmatrix} \hat{\mathbf{Z}}_{zz} \end{pmatrix}^{-1} \begin{pmatrix} \hat{\mathbf{Z}}_{zv} \end{pmatrix} \right] \begin{pmatrix} \hat{\mathbf{I}}_v \end{pmatrix}$$

- it is an imaginary power line without ground wires which would act as a real power line with ground wires
- for impedances transfer to symmetrical components system

Power line with bundle conductors

Bundle conductor

- each phase composed of n partial conductors connected in parallel
- arranged in regular n -polygon
- increases initial corona voltage
- from voltage 400 kV higher

U (kV)	400	750	1150	1800
n	3	4	8	16

- $a_{400\text{kV}} = 40 \text{ cm}$

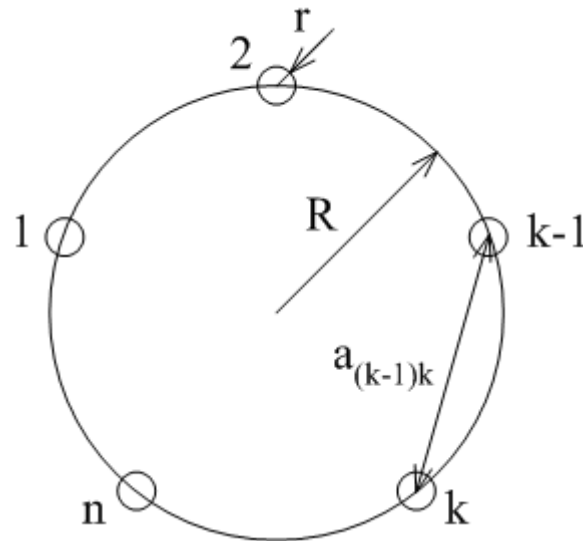

Czech Republic: 400 kV – triple-bundle conductor

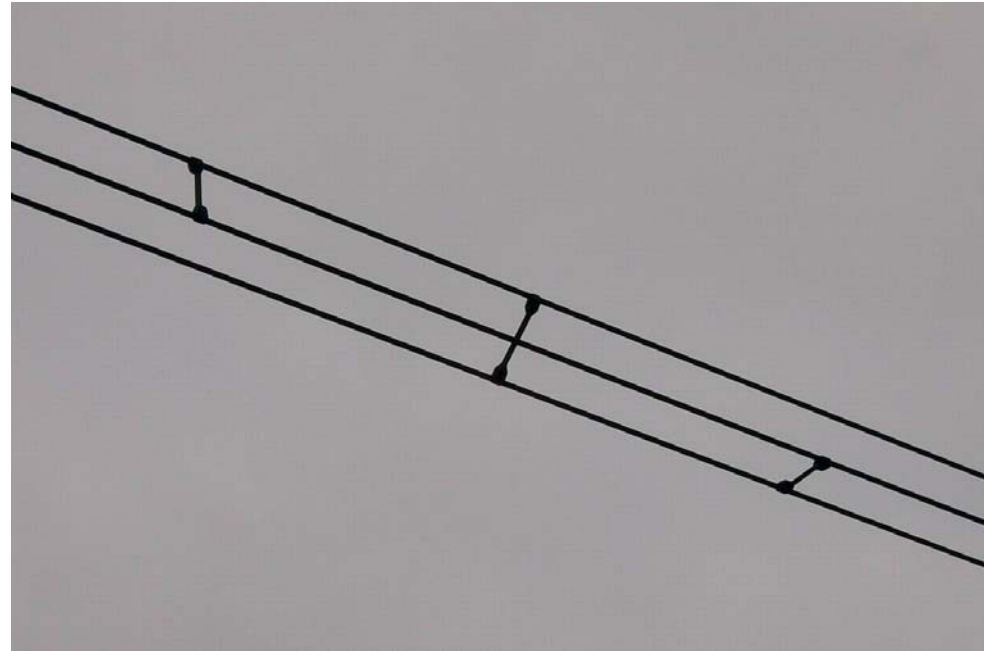

Kladno (CR) 110 kV (2), Canada 750 kV (4), China 1000 kV (8)

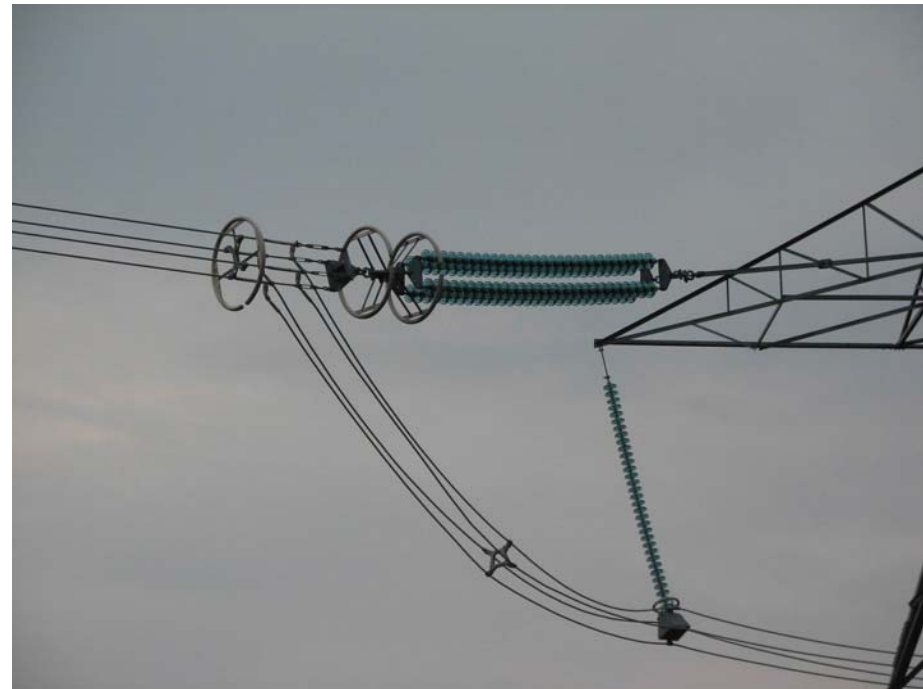

UHV conductor

Operational inductance

$$L_1 = 0,46 \log \frac{d}{\xi_e r_e} \quad (\text{mH / km})$$

equivalent bundle radius

$$r_e = R \sqrt[n]{r \frac{n}{R}}$$

equivalent coefficient

$$\xi_e = \sqrt[n]{\xi}$$

→ bundle conductor decreases L, R (conductors in parallel), increases C

22 kV X ~ 0,35 Ω/km

110 kV X ~ 0,35÷0,4 Ω/km

220 kV X ~ 0,4 Ω/km

400 kV X ~ 0,3 Ω/km

750 kV X ~ 0,25 Ω/km

Zero sequence reactance

- Fe grounding wires - $X_0 \sim (3,5 \div 5,5)X_1$
- ACSR grounding wires - $X_0 \sim (2 \div 4)X_1$

Conductance

It causes active power losses by the conductance to the ground (through insulators, corona – dominant at overhead power lines). It depends on voltage, climatic conditions (p, T, humidity), conductors. Less dependant on loading.

Calculation from corona losses

$$P_S = 3U_f I_S = 3G_1 U_f^2 = G_1 U^2 \quad (\text{W} \cdot \text{km}^{-1})$$

$$G_1 = \frac{P_S}{U^2} \quad (\text{S/km; W/km, V})$$

$$G_1 \approx 10^{-8} \text{ S} \cdot \text{km}^{-1} \quad \times \quad B_1 \approx 10^{-6} \text{ S} \cdot \text{km}^{-1}$$

U (kV)	G ₁ (S/km)	U (kV)	G ₁ (S/km)
110	(3,6 ÷ 5)·10 ⁻⁸	750	(1,3 ÷ 2,5)·10 ⁻⁸
220	(2,5 ÷ 3,6)·10 ⁻⁸	1150	(1,0 ÷ 2)·10 ⁻⁸
400	(1,4 ÷ 2)·10 ⁻⁸		