

Inductors and capacitors in ES

a) Series inductors

- reactors are used to limit short-circuit currents → current limiting reactors
- used in grids up to 35 kV, single-phase ($I_n > 200\text{A}$) or three-phase ($I_n < 200\text{A}$)
- usually air-cooled (small L, no mag. saturation x leakage, mag. field induced current nearby metal objects)
- L optimization (small – lower voltage drop, higher – SC reduction)
- In fault-free state the inductor can be bypassed by a fuse to reduce a voltage drop.
- the same design in LC filters for harmonics suppression, SVC (TCR)



SVC (Static VAr Compensation)

TCR (Thyristor Controlled Reactor)

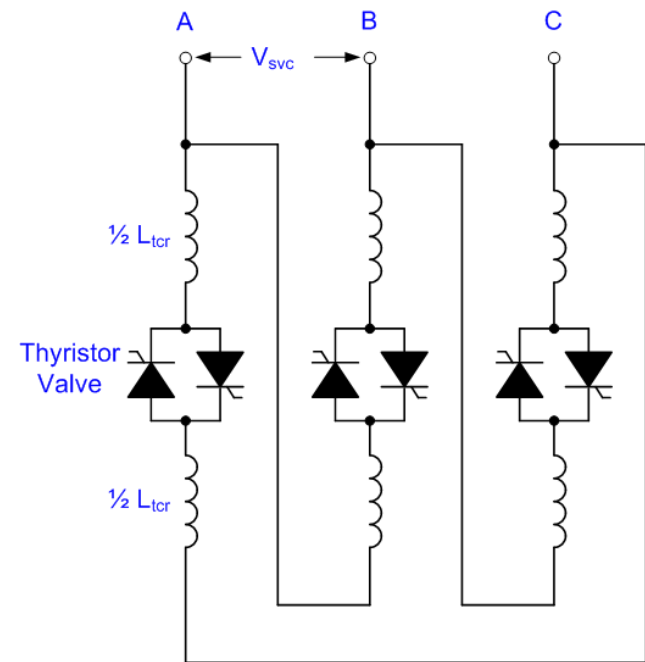
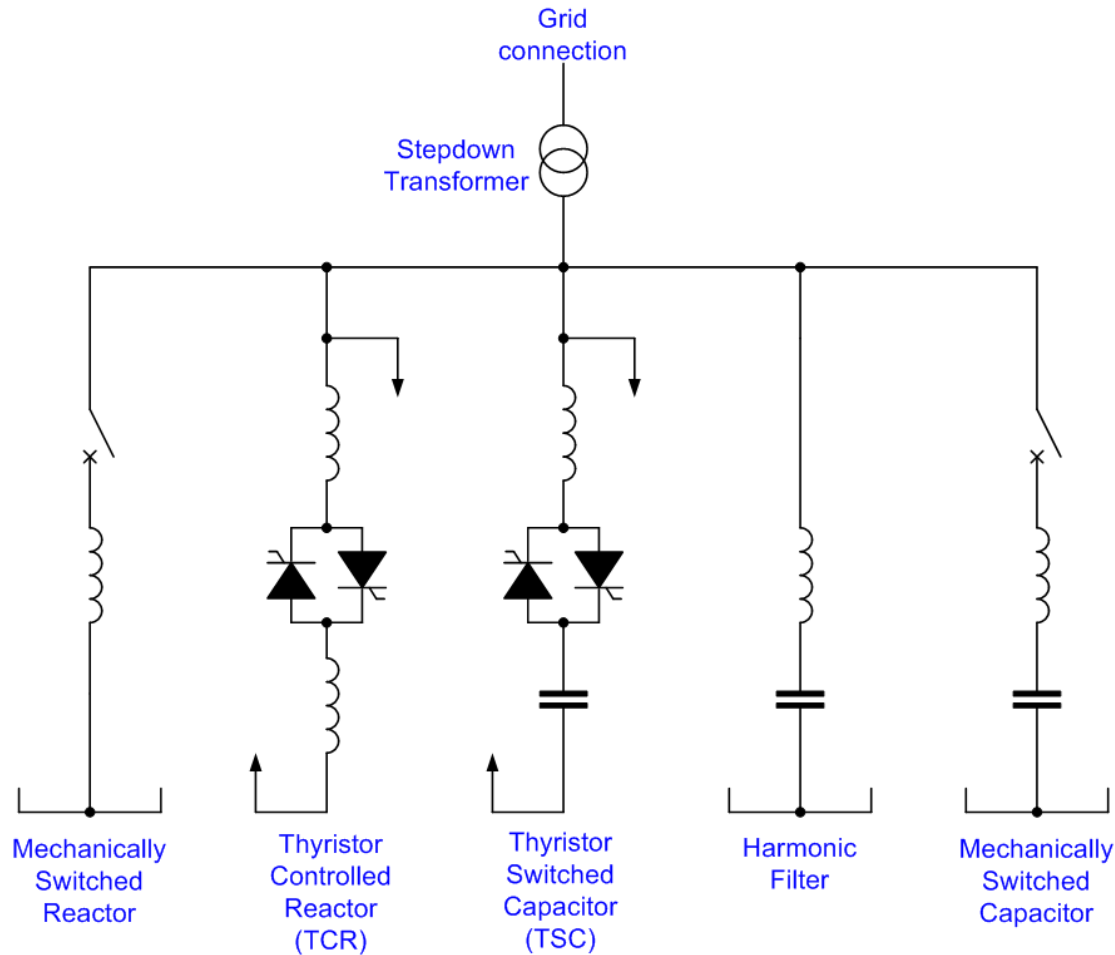



$$R_L \ll X_L$$

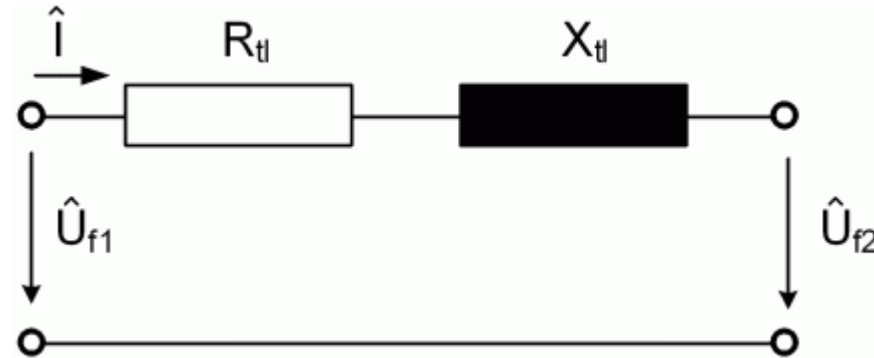

Input: $X_{L\%}$, S_L , U_n , I_n

Calculation: $S_L = \sqrt{3} \cdot U_n \cdot I_n$

$$X_L = \frac{X_{L\%} \cdot U_n}{100 \cdot \sqrt{3} \cdot I_n} = \frac{X_{L\%} \cdot U_n^2}{100 \cdot S_L}$$

$$\Delta \hat{U}_f = \hat{U}_{f1} - \hat{U}_{f2} = (R_L + jX_L) \hat{I} = \hat{Z}_L \hat{I}$$

$$[\hat{Z}_{Labc}] = \hat{Z}_L \cdot [E] - \text{3ph inductor}$$

→ self-impedance \hat{Z}_L , mutual impedances 0

b) Shunt (parallel) inductors

- in the transmission systems (usually $U_N > 220$ kV)
- oil cooling, Fe core
- used to compensate capacitive (charging) currents of long OHL for no-load or small loads → U control:

$$X_L = \frac{U_{Ln}}{\sqrt{3} \cdot I_{Ln}} = \frac{U_{Ln}^2}{Q_{Ln}}$$

$$[\hat{Z}_{Labc}] = \hat{Z}_L \cdot [E]$$

- Q: 15, 30, 55 MVA

Connection in the system:

a) galvanic connection to the line

- Y winding

b) inductor connection to transformer tertiary winding

- lower voltage $U_n \approx 10 \div 35$ kV

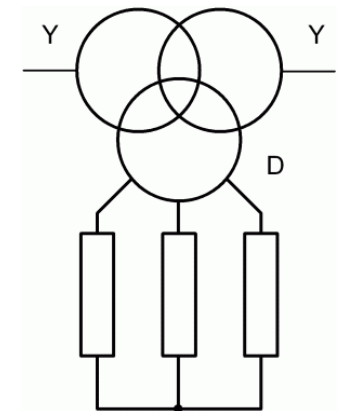
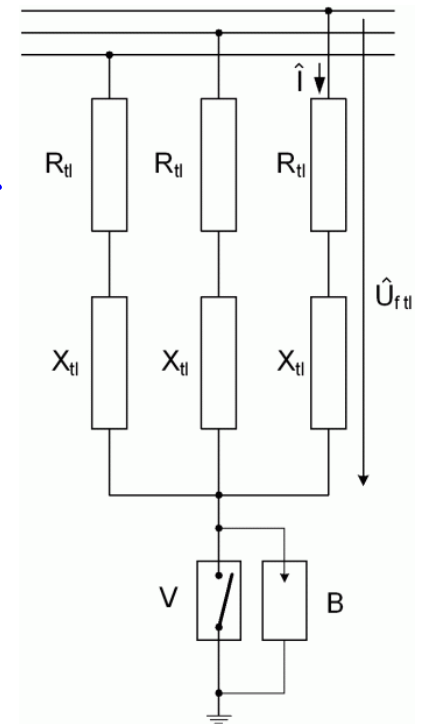

Kočín 400 kV



c) Neutral point inductors

- used in networks with indirectly earthed neutral point to compensate currents during ground fault (capacitive currents)
- resonance compensation
- for distribution systems (6 to 35 kV)
- reactor is single-phased!, oil cooling
- capacitive current change (network reconfiguration) → change in inductance (air gap correction in the magnetic circuit)
= arc-suppression coil (Peterson coil)

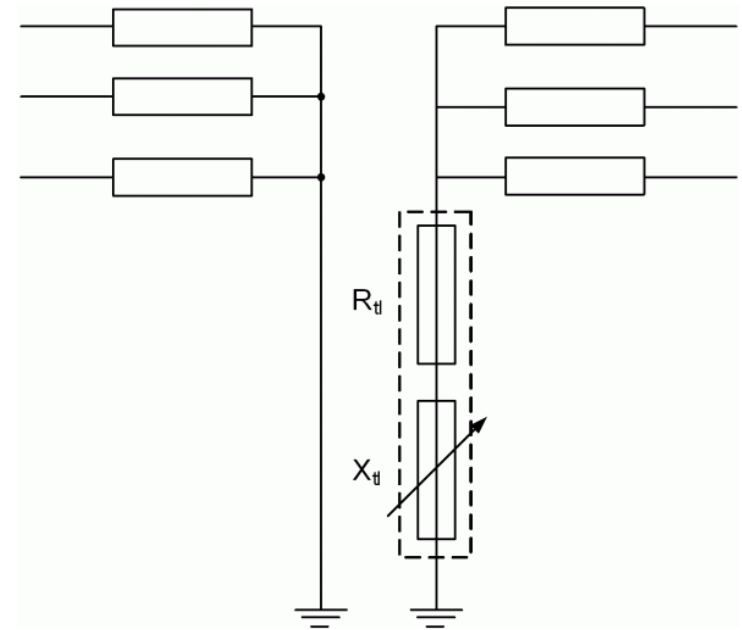

$$X_L = \frac{U_{ph n}}{I_{Lset}}$$

4 MVA, 13 kV, Ostrava – Kunčice



EGE EGE spol. s r.o.
Novohradská 34
České Budějovice

ZHÁSEČÍ TLUMIVKA S PLYNULOU REGULACÍ

TYP **ZTC 4000** VYR. Č. **1802** VDE 0532

CELK. HMOTNOST t **9,40** ART. **ESp**

JMENOVITÉ NAPĚTÍ kV **13,29** HMOTNOST OLEJE t **3,13** ROK VYR. **1971**

KMITOČET Hz **50** HMOTNOST VYJM. DÍLU t **5,00** CHLAZENÍ **ONAN**

JMENOVITÝ VÝKON kVAr **—** JM. PROUD A **—** DOBA ZATÍŽ. **24h**

JMENOVITÝ VÝKON kVAr **4027** JM. PROUD A **30,3-303** DOBA ZATÍŽ. **2h**

IMPEDANCE_{24h} Ω **—** IMPEDANCE_{2h} Ω **438,6-43,9** Um kV **24**

POHON PRO REGULACI kW **1,5** 230/400 V st

SEKUNDÁRNÍ VINUTÍ

SVORKY	NAPĚTÍ	PROUD	VÝKON	DOBA ZATÍŽ.
M2 - N2	V 500 ±10%	A 4500	kVA 2250	6s
M1 - N1	V 100 ±10%	A 3	VA 300	24h

k - I A **300/5** VA **30** TRÍDA **1FS5**

SCHEMA ZAPOJENÍ

D1 - D2 HLAVNÍ VINUTÍ
M2 - N2 VÝKONOVĚ POMOCNÉ VINUTÍ
M1 - N1 MĚŘICÍ POMOCNÉ VINUTÍ
k-I - SEKUNDÁRNÍ SVORKY PROUDOVÉHO TRANSFORMÁTORU

d) Series capacitors

- capacitors in ES = capacitor banks
- in series → reduce TS line series inductance
- power flow control, voltage drop reduction, dynamic oscillation mitigation
- TCSR (Thyristor Controlled Series Capacitor)

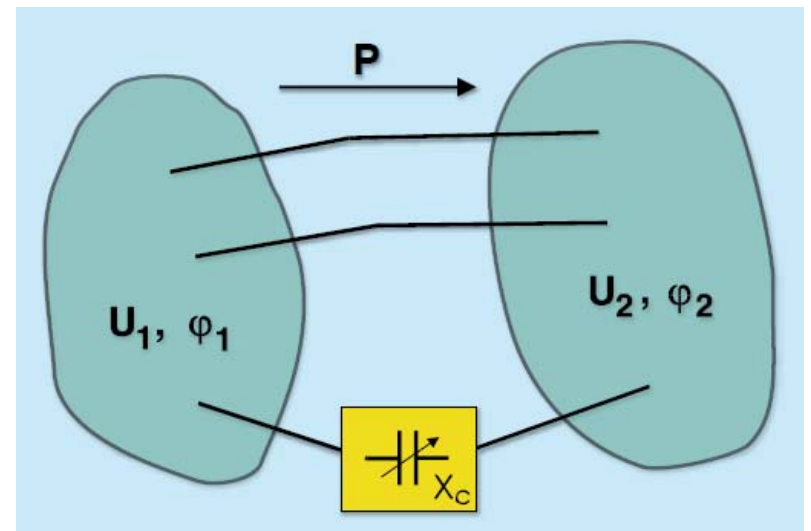
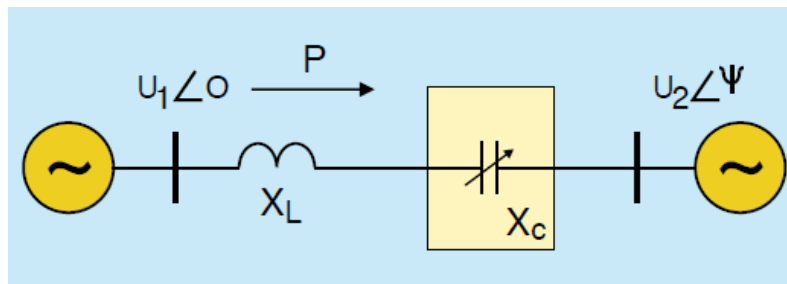
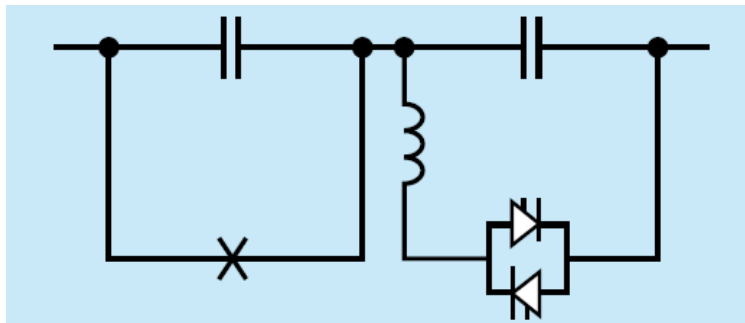

$$\hat{U}_c = -j \frac{1}{\omega C} \hat{I}$$

- device installed on insulated platforms – C under voltage
- during short-circuits and overcurrents there appears overvoltage on the capacitor (very fast protections are used)

Canada 750 kV



e) Shunt capacitors

- used in LV industrial networks (up to 1 kV)
- connection:
 - a) wye - Y
 - b) delta - Δ (D)

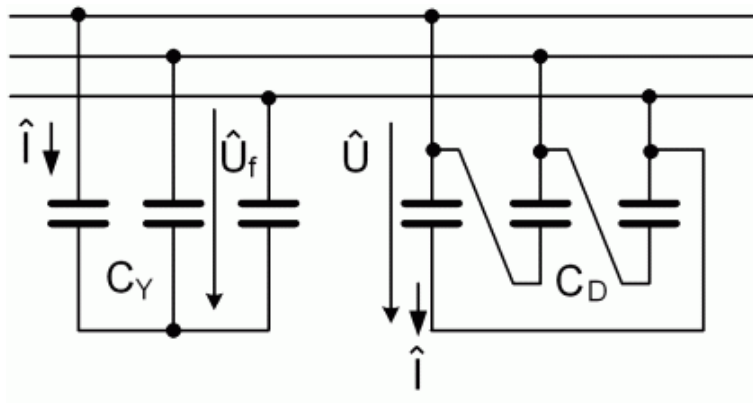

$$Q_f = U_f \cdot I_C = U_f^2 \omega C_Y \quad Q_f = U \cdot I_C = U^2 \omega C_\Delta$$

$$Q = 3U_f^2 \omega C_Y = U^2 \omega C_Y \quad Q = 3U^2 \omega C_\Delta$$

- with the same reactive power

$$U^2 \omega C_Y = 3U^2 \omega C_\Delta \rightarrow C_Y = 3C_\Delta \rightarrow \text{rather delta}$$

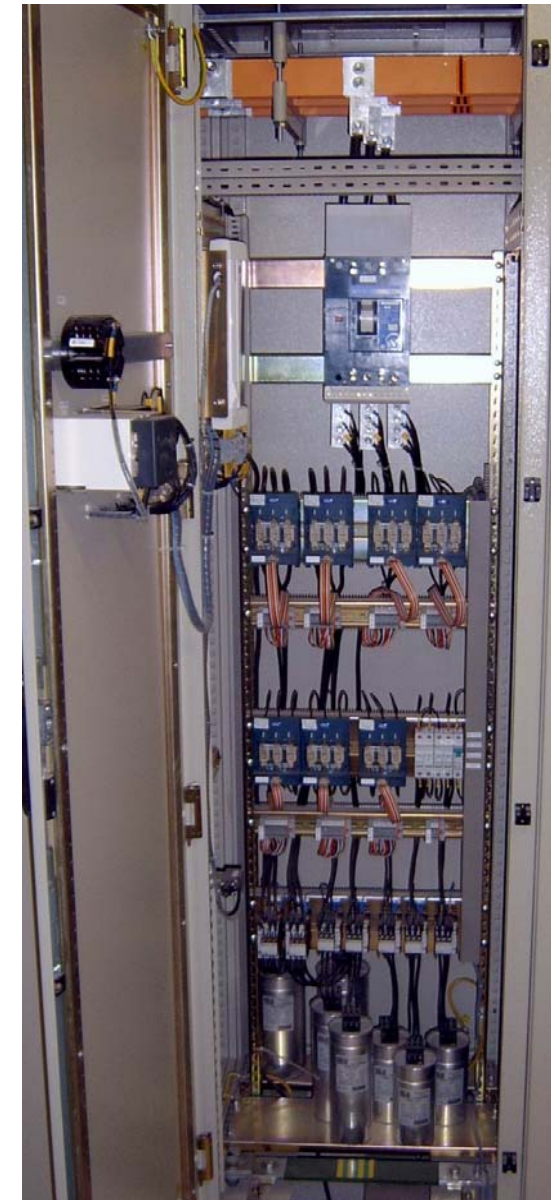

- power factor improvement, lower power losses, voltage drops
- individual or group compensation could be used

- shunt – also in harmonic filter (mainly MV, or SVC to HV via transformer)

Transformer Concept in CR

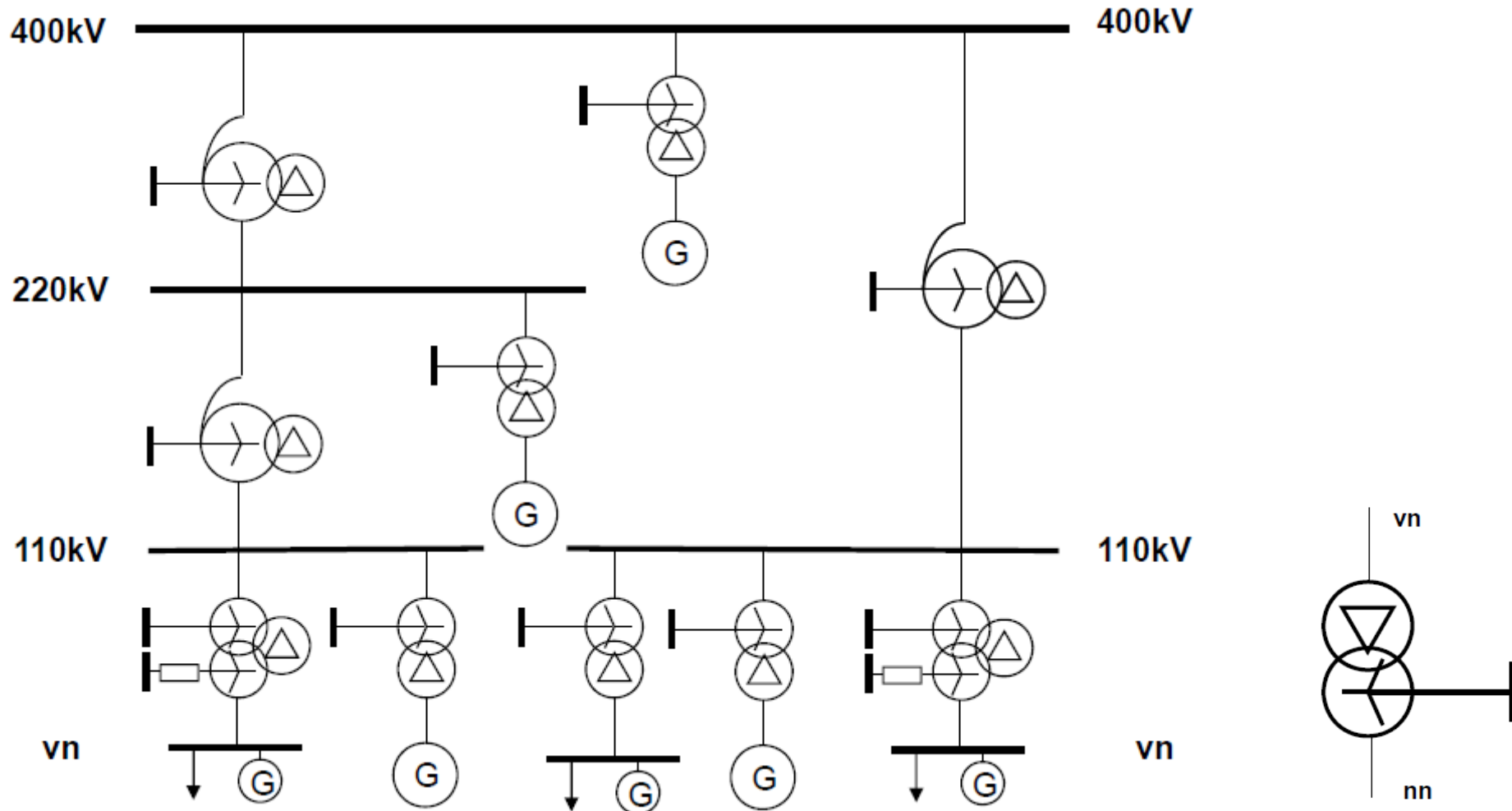

- voltages, neutral point grounding, winding connection + D winding

Transformers in ES

DTS 22/0,4 kV (35/0,4 kV)

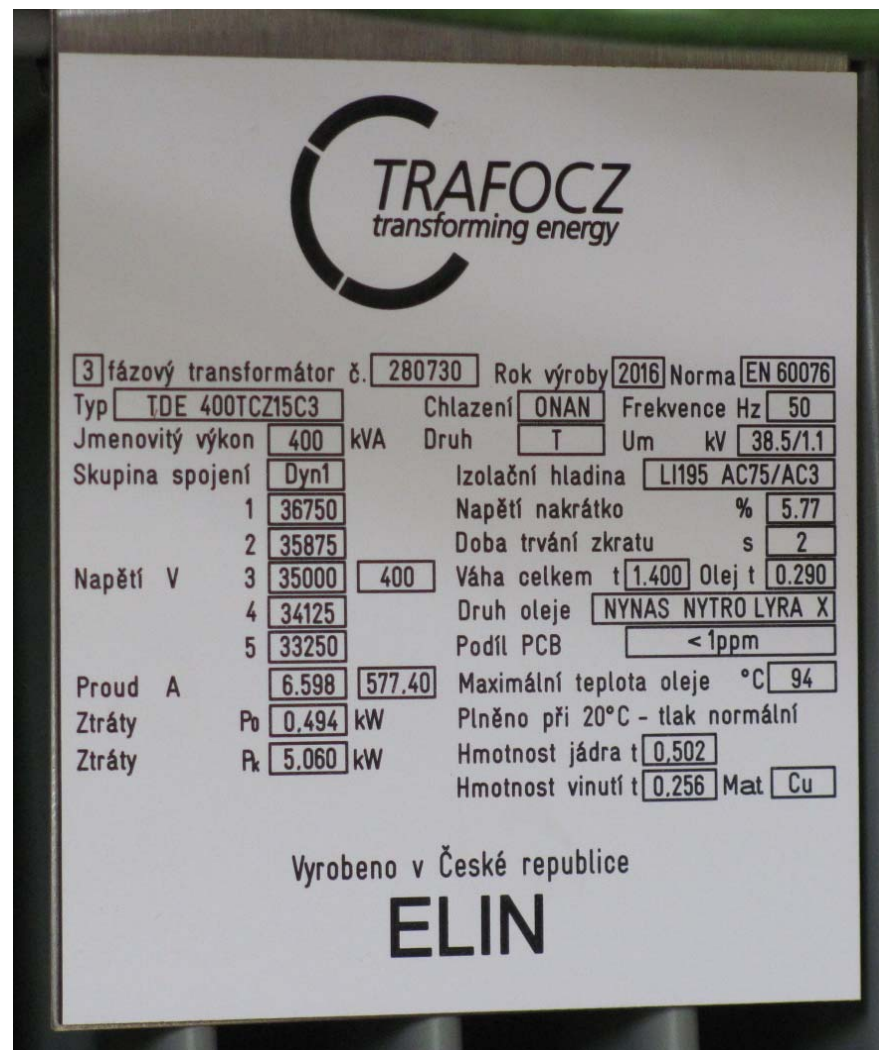



Industrial (22/6 kV)



110/22 kV



350 MVA, 400/110 kV
YNauto - d1, Sokolnice

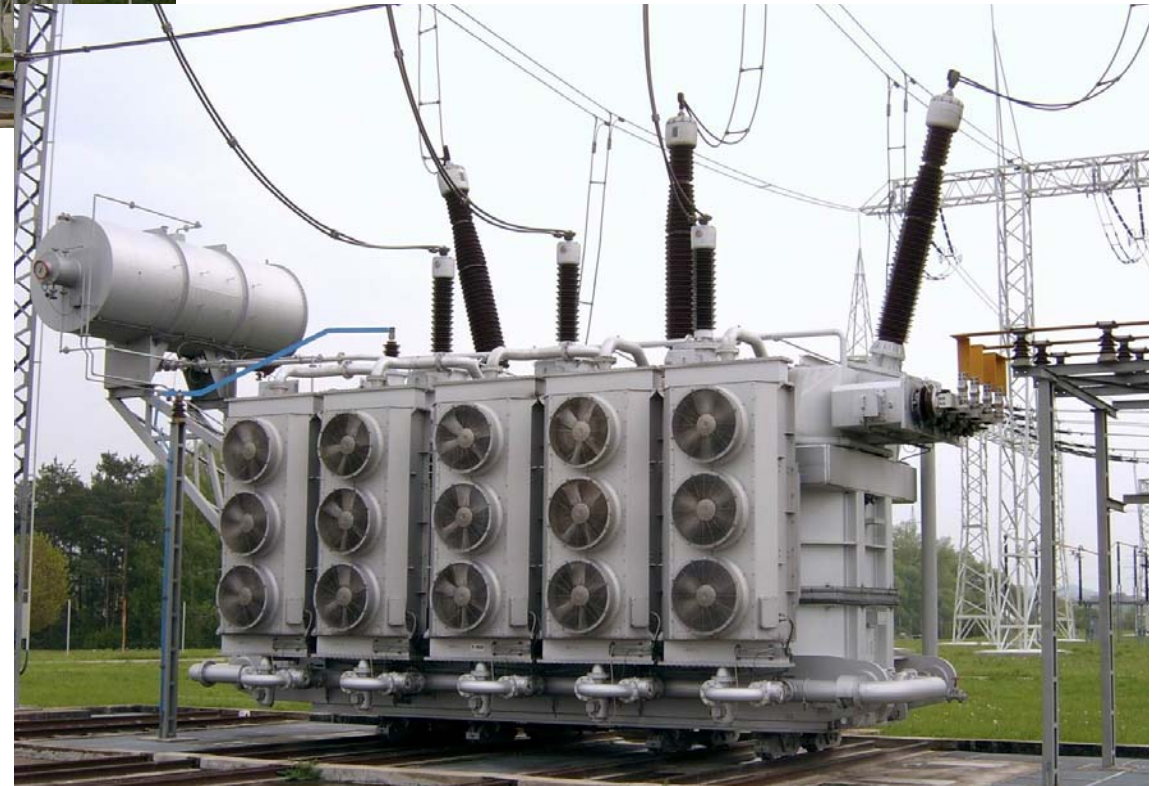
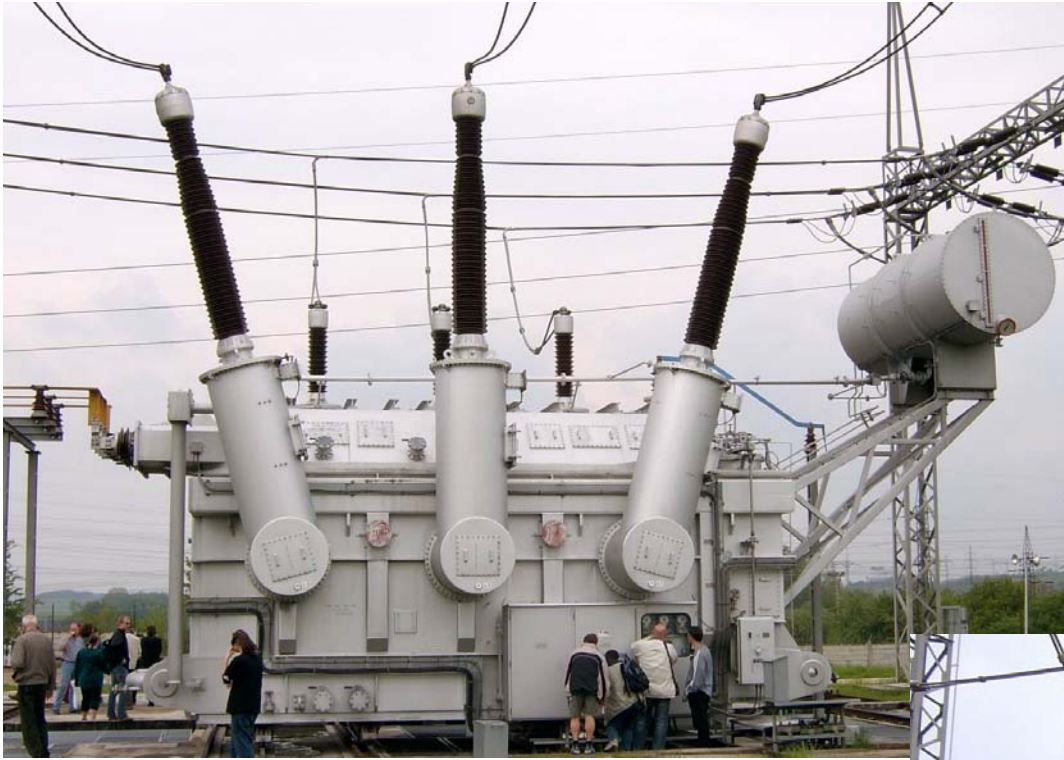







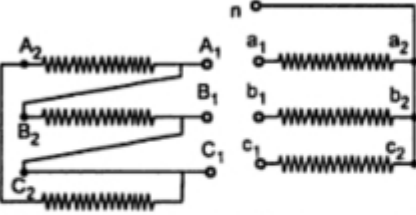
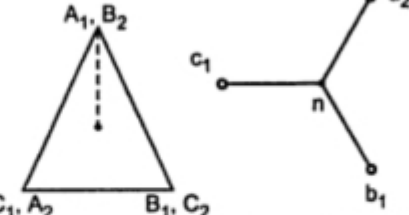

Construction Issues

- winding material (Al, Cu)
- winding connection (D, Y, Z)
- clock hour number (phasor group) (1-11)
- core material (standard, amorphous) → no load losses
- tank (oil, dry)
- cooling (oil, air) – e.g. ONAN, OFAF
- noise
- weight
- voltage levels, ratio
- power
 - DTS: **50**, 63, **100**, **160**, **250**, **400**, 500, **630**, 800, 1000, 1250, 1600, 2000, 2500, 4000 kVA
 - 110 kV/MV: 10, 16, **25**, **40**, 50, 63 MVA
 - HV/MV: 66, 200, **250**, **350**
- parameters ...

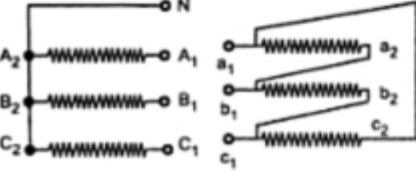
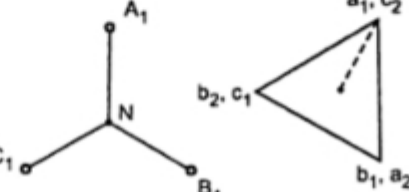
a) Two-winding transformers

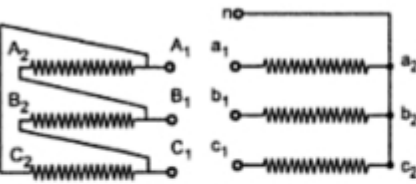
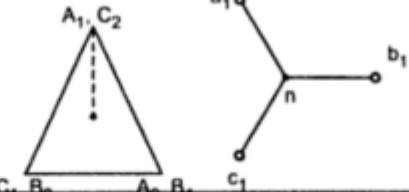
- winding connection Y, Yn, D, Z, Zn, V
 - Yzn – distribution TRF MV/LV up to 250 kVA, for unbalanced load
 - Dyn – distribution TRF MV/LV from 400 kVA
 - YNyd – power grid transformer (e.g. 110/23/6,3 kV)
 - Yna-d, YNynd – power grid transformer (400, 220, 110 kV)
 - Yd – block TRF in power plants, the 3rd harmonic suppression

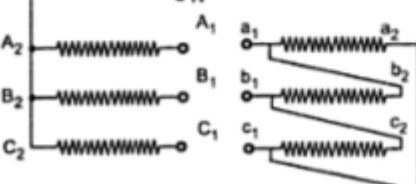
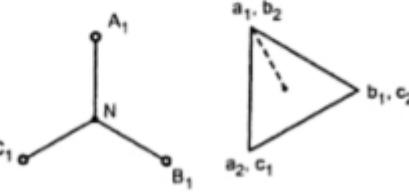
- clock hour number (phasor group)

Sr. No.	Symbol	Windings and terminals	EMF vector diagrams	Equivalent clock method representation
5.	D y 1 -30°			
6.	Y d 1 -30°			
7.	D y 11 +30°			
8.	Y d 11 +30°			

- equivalent circuit: T – network

$$\hat{Z}_{\sigma p} = R_p + jX_{\sigma p} \quad \hat{Z}_{\sigma s} = R_s + jX_{\sigma s} \quad \hat{Y}_q = G_q - jB_q$$

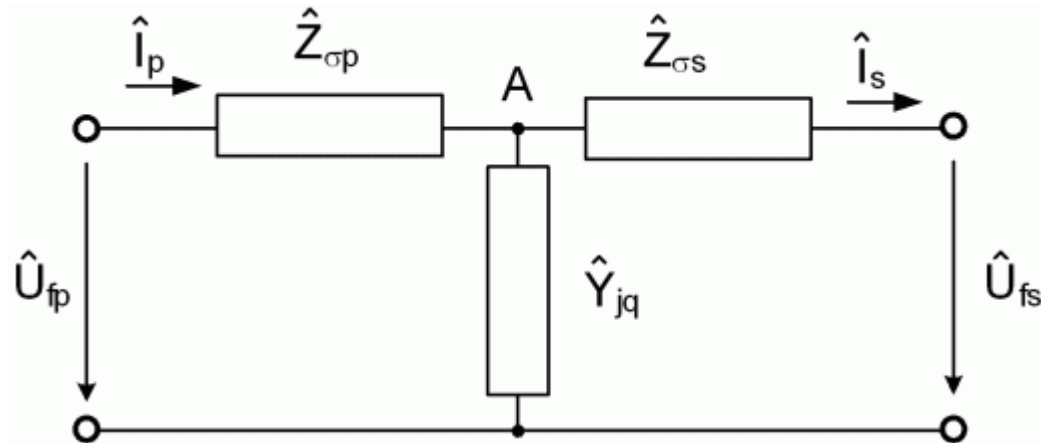

- each phase can be considered separately (unbalance is neglected)
- further operational impedance discussed
- values of the parameters are calculated, then verified by two tests
 - *no-load test* – secondary winding open, primary winding supplied by rated voltage, no-load current is flowing (lower than rated current)
 - *short-circuit test* – secondary winding short-circuited, primary winding supplied by short-circuit voltage (lower than rated voltage), so that rated current is flowing

ΔP_0 (W), i_0 (%), ΔP_k (W), $z_k = u_k$ (%), S_n (VA), U_n (V)
 $u_k \approx 4 \div 17$ % (increases with TRF power)
 $p_k \approx 0,1 \div 1$ % (decreases with TRF power)
 $p_0 \approx 0,01 \div 0,1$ % (decreases with TRF power)

- shunt branch:

$$g_q = \frac{\Delta P_0}{S_n} \quad y_q = \frac{i_{0\%}}{100} \quad b_q = \sqrt{y_q^2 - g_q^2}$$

$$\hat{y}_q = \frac{\Delta P_0}{S_n} - j \sqrt{\left(\frac{i_{0\%}}{100}\right)^2 - \left(\frac{\Delta P_0}{S_n}\right)^2} = g_q - j \cdot b_q$$

$$\hat{Y}_q = \hat{y}_q \frac{S_n}{U_n^2} = \frac{S_n}{U_n^2} \left[\frac{\Delta P_0}{S_n} - j \sqrt{\left(\frac{i_{0\%}}{100}\right)^2 - \left(\frac{\Delta P_0}{S_n}\right)^2} \right] = G_q - j \cdot B_q$$

- series branch:

$$r_k = \frac{\Delta P_k}{S_n} \quad z_k = \frac{u_{k\%}}{100} \quad x_k = \sqrt{z_k^2 - r_k^2}$$

$$\hat{z}_k = \frac{\Delta P_k}{S_n} + j \sqrt{\left(\frac{u_{k\%}}{100}\right)^2 - \left(\frac{\Delta P_k}{S_n}\right)^2} = r_k + j \cdot x_k$$

$$\hat{Z}_k = \hat{z}_k \frac{U_n^2}{S_n} = \frac{U_n^2}{S_n} \left[\frac{\Delta P_k}{S_n} + j \sqrt{\left(\frac{u_{k\%}}{100}\right)^2 - \left(\frac{\Delta P_k}{S_n}\right)^2} \right] = R_k + j \cdot X_k$$

$$\hat{Z}_{\sigma ps} = \hat{Z}_k = (R_p + R_s) + j(X_{\sigma p} + X_{\sigma s})$$

- we choose $\hat{Z}_{\sigma p} = 0,5\hat{Z}_{\sigma ps} = \hat{Z}_{\sigma s}$

- this division is not physically correct (different leakage flows, different resistances)



3 fázový transformátor č. 280730 Rok výroby 2016 Norma EN 60076
Typ TDE 400TCZ15C3 Chlazení ONAN Frekvence Hz 50
Jmenovitý výkon 400 kVA Druh T Um kV 38.5/1.1
Skupina spojení Dyn1 Izolační hladina LI195 AC75/AC3
1 36750 Napětí nakrátko % 5.77
2 35875 Doba trvání zkratu s 2
Napětí V 3 35000 400 Váha celkem t 1.400 Olej t 0.290
4 34125 Druh oleje NYNAS NYTRO LYRA X
5 33250 Podíl PCB < 1ppm
Proud A 6.598 577.40 Maximální teplota oleje °C 94
Ztráty P₀ 0.494 kW Plněno při 20°C - tlak normální
Ztráty P_k 5.060 kW Hmotnost jádra t 0.502
Hmotnost vinutí t 0.256 Mat Cu

Vyrobeno v České republice

ELIN

Transformer losses and efficiency

$\Delta P_0 \approx U$ - constant during operation

$\Delta P_k \cong R \cdot I^2 \approx I^2$ - changing during operation

- efficiency $\eta = \frac{P_{\text{out}}}{P_{\text{in}}} = 1 - \frac{\Delta P_0 + \Delta P_k}{P_{\text{in}}}$

$$\eta = 1 - \frac{\Delta P_0 + R \cdot I^2}{U_n \cdot I \cdot \cos \varphi} = 1 - \frac{\Delta P_0}{U_n \cdot I \cdot \cos \varphi} - \frac{R \cdot I}{U_n \cdot \cos \varphi}$$

$$\frac{d\eta}{dI} = 0 + \frac{\Delta P_0}{U_n \cdot I^2 \cdot \cos \varphi} - \frac{R}{U_n \cdot \cos \varphi} \stackrel{!}{=} 0$$

$$\frac{\Delta P_0}{U_n \cdot I^2 \cdot \cos \varphi} \stackrel{!}{=} \frac{R}{U_n \cdot \cos \varphi}$$

$$\underline{\Delta P_0 \stackrel{!}{=} R I^2 = \Delta P_k}$$

b) Three-winding transformers

- parameters are calculated, then verified by no-load and short-circuit measurements (3 short-circuit tests: 1 winding no-load, 1 short-circuit and 1 supplied):

$$\Delta P_0 \text{ (W)}, i_0 \text{ (\%)}, \Delta P_k \text{ (W)}, z_K = u_K \text{ (\%)},$$

$$S_n \text{ (VA)}, U_n \text{ (V)}$$

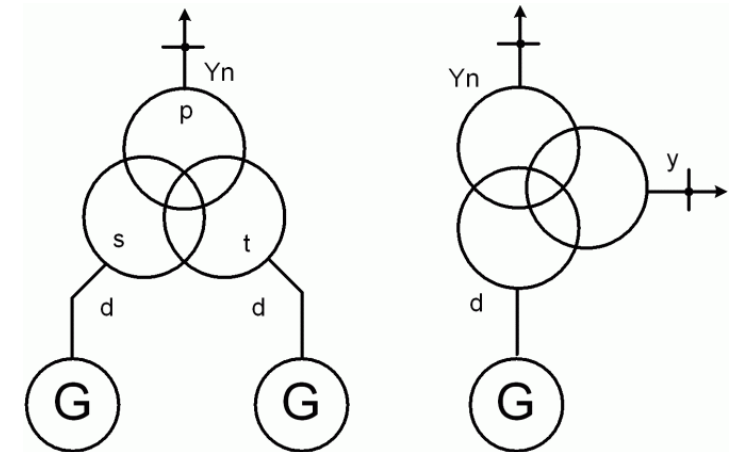

- powers needn't be the same: $S_{S_n} = S_{T_n} = 0,5 \cdot S_{P_n}$
- equivalent circuit:

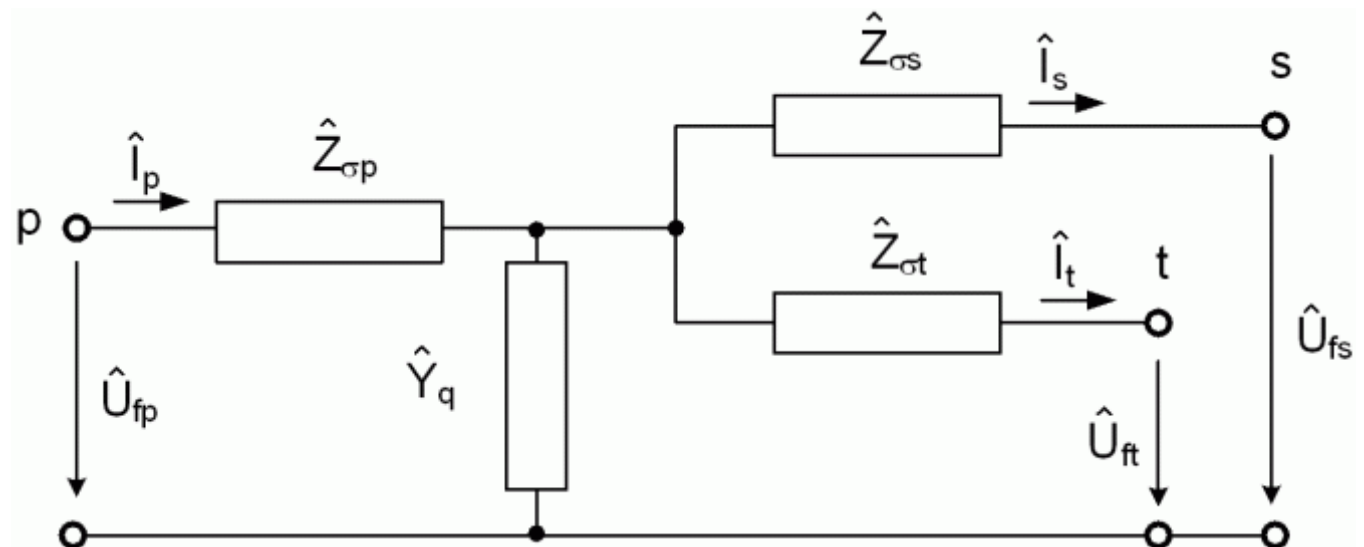

- no-load measurement:

related to the primary rated power and rated voltage S_{Pn} a U_{PN} (supplied)

$$\hat{y}_q = g_q - j \cdot b_q = \frac{\Delta P_0}{S_{Pn}} - j \sqrt{\left(\frac{i_{0\%}}{100}\right)^2 - \left(\frac{\Delta P_0}{S_{Pn}}\right)^2}$$

denominated value (S) – related to U_{PN}

$$\hat{Y}_q = \hat{y}_q \frac{S_{Pn}}{U_{Pn}^2} = G_q - j \cdot B_q = \frac{S_{Pn}}{U_{Pn}^2} \left[\frac{\Delta P_0}{S_{Pn}} - j \sqrt{\left(\frac{i_{0\%}}{100}\right)^2 - \left(\frac{\Delta P_0}{S_{Pn}}\right)^2} \right]$$

- short-circuit measurement: (3x, supply – short-circuit – no-load)

provided: $S_{Pn} \neq S_{Sn} \neq S_{Tn}$

measurement between	P - S	P - T	S - T
short-circuit losses (W)	ΔP_{kPS}	ΔP_{kPT}	ΔP_{kST}
short-circuit voltage (%)	u_{kPS}	u_{kPT}	u_{kST}
measurement corresponds to power (VA)	S_{Sn}	S_{Tn}	S_{Tn}

short-circuit tests S – T:

parameter to be found:

$$\hat{Z}_{ST} = \hat{Z}_{\sigma S} + \hat{Z}_{\sigma T} \quad \left(\hat{Z}_{\sigma S} = R_S + j \cdot X_{\sigma S} \right) \text{ - recalculated to } U_{PN}$$

$$\hat{Z}_{ST} = \hat{Z}_{\sigma S} + \hat{Z}_{\sigma T} \text{ - recalculated to } U_{PN}, S_{PN}$$

$$\Delta P_k \text{ for } I_{Tn} \rightarrow \Delta P_{kST} = 3 \cdot R_{ST}^+ \cdot I_{Tn}^2, \quad I_{Tn} = \frac{S_{Tn}}{\sqrt{3} \cdot U_{Tn}}$$

R_{ST}^+resistance of secondary and tertiary windings (related to U_{Tn})

$$R_{ST}^+ = \frac{\Delta P_{kST}}{S_{Tn}^2} \cdot U_{Tn}^2$$

$$R_{ST} = R_{ST}^+ \cdot \frac{U_{Pn}^2}{U_{Tn}^2} \rightarrow R_{ST} = R_S + R_T = \frac{\Delta P_{kST}}{S_{Tn}^2} \cdot U_{Pn}^2$$

r_S (r_T)...resistance of sec. and ter. windings recalculated to primary

$$r_{ST} = R_{ST} \cdot \frac{S_{PN}}{U_{Pn}^2} = \frac{\Delta P_{kST}}{S_{Tn}^2} \cdot S_{PN}$$

- impedance:

$$Z_{ST} = \frac{u_{kST\%}}{100} \cdot \frac{S_{Pn}}{S_{Tn}}, \quad Z_{ST} = z_{ST} \cdot \frac{U_{Pn}^2}{S_{Pn}} = \frac{u_{kST\%}}{100} \cdot \frac{U_{Pn}^2}{S_{Tn}}$$

$$\hat{Z}_{ST} = r_{ST} + j \cdot X_{ST}, \quad X_{ST} = \sqrt{Z_{ST}^2 - r_{ST}^2}, \quad X_{ST} = X_{\sigma S} + X_{\sigma T}$$

- based on the derived relations we can write:

P - S:

$$\hat{Z}_{PS} = r_{PS} + j \cdot X_{PS} = \frac{\Delta P_{kPS}}{S_{Sn}^2} \cdot S_{Pn} + j \cdot \sqrt{\left(\frac{u_{kPS\%}}{100} \cdot \frac{S_{Pn}}{S_{Sn}} \right)^2 - \left(\frac{\Delta P_{kPS}}{S_{Sn}^2} \cdot S_{Pn} \right)^2}$$

$$\hat{Z}_{PS} = R_{PS} + j \cdot X_{PS} = \frac{\Delta P_{kPS}}{S_{Sn}^2} \cdot U_{Pn}^2 + j \cdot \sqrt{\left(\frac{u_{kPS\%}}{100} \cdot \frac{U_{Pn}^2}{S_{Sn}} \right)^2 - \left(\frac{\Delta P_{kPS}}{S_{Sn}^2} \cdot U_{Pn}^2 \right)^2}$$

- analogous for P – T and S – T

- leakage reactances for P, S, T:

$$\hat{Z}_{\sigma P} = R_P + j \cdot X_{\sigma P} = 0,5 \cdot (\hat{Z}_{PS} + \hat{Z}_{PT} - \hat{Z}_{ST})$$

$$\hat{Z}_{\sigma S} = R_S + j \cdot X_{\sigma S} = 0,5 \cdot (\hat{Z}_{PS} + \hat{Z}_{ST} - \hat{Z}_{PT})$$

$$\hat{Z}_{\sigma T} = R_T + j \cdot X_{\sigma T} = 0,5 \cdot (\hat{Z}_{PT} + \hat{Z}_{ST} - \hat{Z}_{PS})$$

- knowledge of the series impedances and shunt admittances allows to study voltage and power conditions of 3-winding transformers

Symmetrical system components

Decomposition of unsymmetrical (unbalanced) voltage:

$$\hat{U}_A = \hat{U}_{A1} + \hat{U}_{A2} + \hat{U}_{A0}$$

$$\hat{U}_B = \hat{U}_{B1} + \hat{U}_{B2} + \hat{U}_{B0}$$

$$\hat{U}_C = \hat{U}_{C1} + \hat{U}_{C2} + \hat{U}_{C0}$$

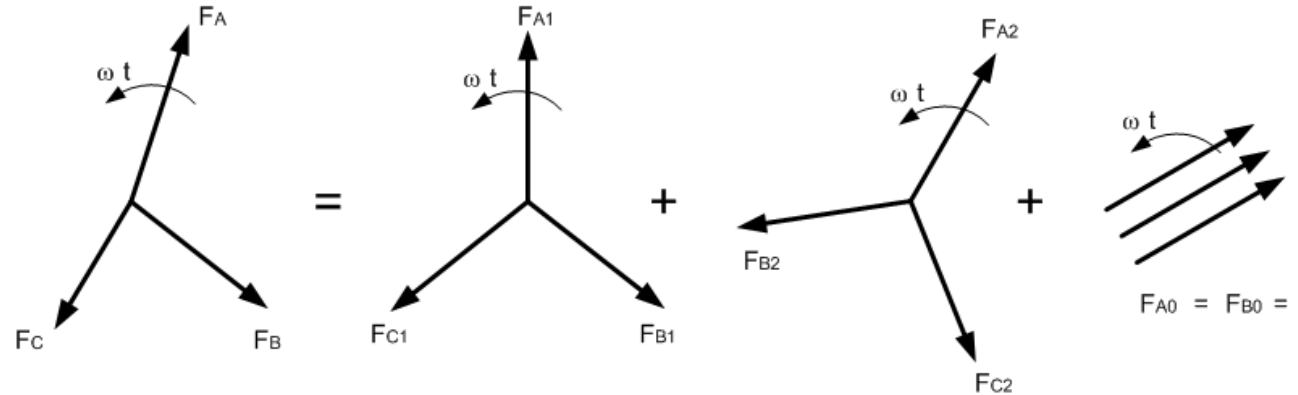

Positive sequence (1), negative (2) and zero (0) sequence.

Hence (reference phase A)

$$\hat{U}_A = \hat{U}_1 + \hat{U}_2 + \hat{U}_0$$

$$\hat{U}_B = \hat{a}^2 \hat{U}_1 + \hat{a} \hat{U}_2 + \hat{U}_0$$

$$\hat{U}_C = \hat{a} \hat{U}_1 + \hat{a}^2 \hat{U}_2 + \hat{U}_0$$

$$\hat{I}_A = \hat{I}_1 + \hat{I}_2 + \hat{I}_0$$

$$\hat{I}_B = \hat{a}^2 \hat{I}_1 + \hat{a} \hat{I}_2 + \hat{I}_0$$

$$\hat{I}_C = \hat{a} \hat{I}_1 + \hat{a}^2 \hat{I}_2 + \hat{I}_0$$

where $\hat{a} = -\frac{1}{2} + j\frac{\sqrt{3}}{2} = e^{j\frac{2\pi}{3}}$

$$\hat{a}^2 = -\frac{1}{2} - j\frac{\sqrt{3}}{2} = e^{j\frac{4\pi}{3}}$$

Matrix

$$(\mathbf{U}_{ABC}) = \begin{pmatrix} \hat{U}_A \\ \hat{U}_B \\ \hat{U}_C \end{pmatrix} = \begin{pmatrix} 1 & 1 & 1 \\ \hat{a}^2 & \hat{a} & 1 \\ \hat{a} & \hat{a}^2 & 1 \end{pmatrix} \begin{pmatrix} \hat{U}_1 \\ \hat{U}_2 \\ \hat{U}_0 \end{pmatrix} = (\mathbf{T})(\mathbf{U}_{120})$$

Inversely

$$(\mathbf{U}_{120}) = \begin{pmatrix} \hat{U}_1 \\ \hat{U}_2 \\ \hat{U}_0 \end{pmatrix} = \frac{1}{3} \begin{pmatrix} 1 & \hat{a} & \hat{a}^2 \\ 1 & \hat{a}^2 & \hat{a} \\ 1 & 1 & 1 \end{pmatrix} \begin{pmatrix} \hat{U}_A \\ \hat{U}_B \\ \hat{U}_C \end{pmatrix} = (\mathbf{T}^{-1})(\mathbf{U}_{ABC})$$

Series symmetrical segments in ES

$$\begin{pmatrix} \Delta \hat{U}_A \\ \Delta \hat{U}_B \\ \Delta \hat{U}_C \end{pmatrix} = \begin{pmatrix} \hat{Z} & \hat{Z}' & \hat{Z}' \\ \hat{Z}' & \hat{Z} & \hat{Z}' \\ \hat{Z}' & \hat{Z}' & \hat{Z} \end{pmatrix} \begin{pmatrix} \hat{I}_A \\ \hat{I}_B \\ \hat{I}_C \end{pmatrix}$$

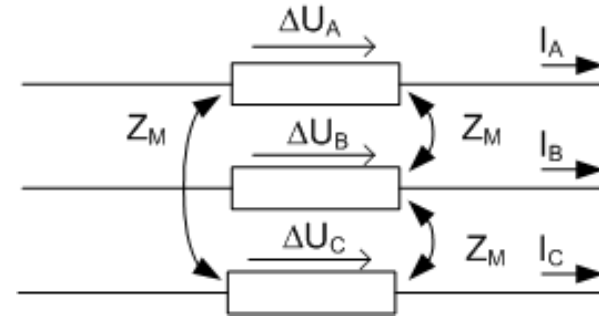

$$(\Delta U_{ABC}) = (Z_{ABC})(I_{ABC})$$

$$(T)(\Delta U_{120}) = (Z_{ABC})(T)(I_{120})$$

$$(\Delta U_{120}) = (T)^{-1}(Z_{ABC})(T)(I_{120}) = (Z_{120})(I_{120})$$

$$(Z_{120}) = (T)^{-1}(Z_{ABC})(T)$$

$$(Z_{120}) = \begin{pmatrix} \hat{Z}_1 & 0 & 0 \\ 0 & \hat{Z}_2 & 0 \\ 0 & 0 & \hat{Z}_0 \end{pmatrix} = \begin{pmatrix} \hat{Z} - \hat{Z}' & 0 & 0 \\ 0 & \hat{Z} - \hat{Z}' & 0 \\ 0 & 0 & \hat{Z} + 2\hat{Z}' \end{pmatrix}$$

Shunt symmetrical segments in ES

$$(\mathbf{U}_{ABC}) = (\mathbf{Z}_{ABC})(\mathbf{I}_{ABC}) + (\mathbf{Z}_N)(\mathbf{I}_{ABC})$$

$$(\mathbf{Z}_N) = \begin{pmatrix} \hat{Z}_N & \hat{Z}_N & \hat{Z}_N \\ \hat{Z}_N & \hat{Z}_N & \hat{Z}_N \\ \hat{Z}_N & \hat{Z}_N & \hat{Z}_N \end{pmatrix}$$

$$(\mathbf{U}_{120}) = (\mathbf{T})^{-1}(\mathbf{Z}_{ABC})(\mathbf{T})(\mathbf{I}_{120}) + (\mathbf{T})^{-1}(\mathbf{Z}_N)(\mathbf{T})(\mathbf{I}_{120})$$

$$(\mathbf{Z}_{120}) = (\mathbf{T})^{-1}[(\mathbf{Z}_{ABC}) + (\mathbf{Z}_N)](\mathbf{T})$$

$$(\mathbf{Z}_{120}) = \begin{pmatrix} \hat{Z} - \hat{Z}' & 0 & 0 \\ 0 & \hat{Z} - \hat{Z}' & 0 \\ 0 & 0 & \hat{Z} + 2\hat{Z}' + 3Z_N \end{pmatrix}$$

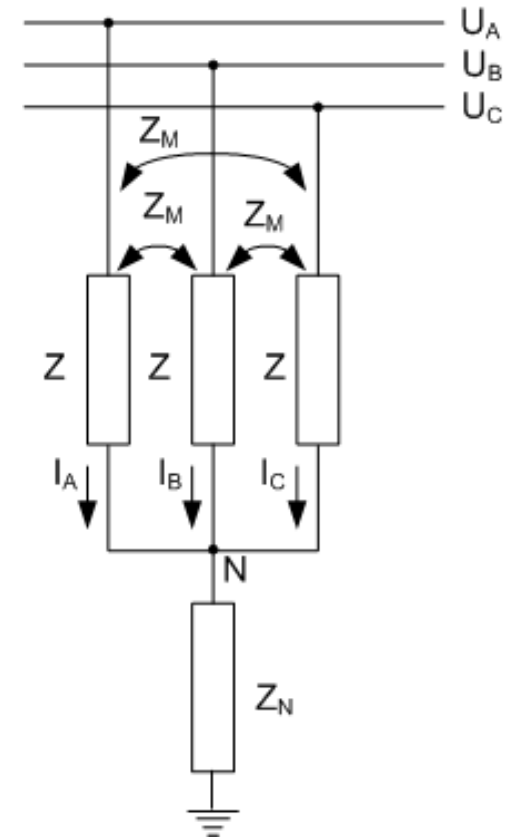

Symmetrical components voltages in the symmetrical segments depend only on the corresponding component current and component impedance.

Transformers zero sequence impedances

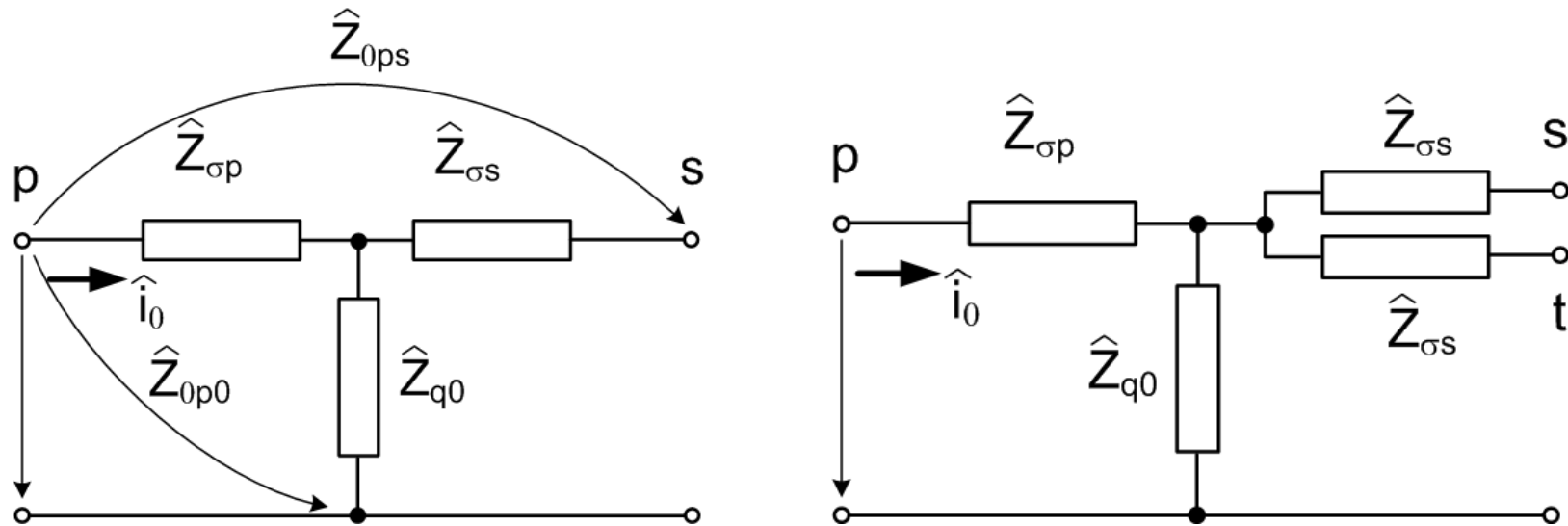

Series parameters are the same as for the positive sequence, the shunt always need to be determined.

Assumptions:

- Zero sequence voltage supplies the primary winding.
- The relative values are related to U_{PN} and S_{PN} .
- We distinguish free and tied magnetic flows (core x shell TRF).

Z_0 depends on the winding connection.

a) Y / any connection

$$3i_0 = 0$$

$$Z_0 = \frac{u_0}{i_0} \rightarrow \infty$$

$$Z_{0p0} \rightarrow \infty$$

$$Z_{0ps} \rightarrow \infty$$

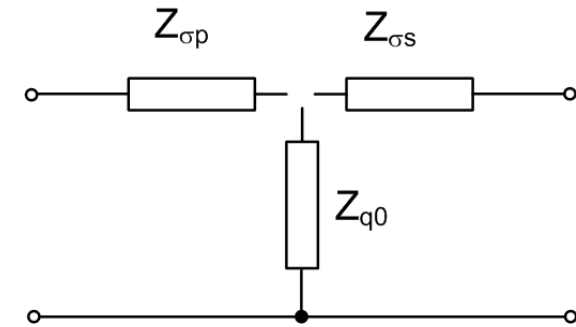
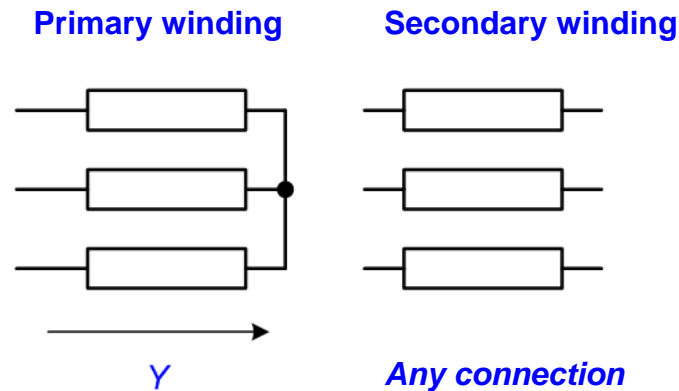

b) D / any connection

Zero sequence voltage is attached to D \rightarrow voltage at each phase

$$u_0 - u_0 = 0 \rightarrow i_a = i_b = i_c = 0 \rightarrow i_0 = 0$$

$$Z_0 = \frac{u_0}{i_0} \rightarrow \infty$$

$$Z_{0p0} \rightarrow \infty$$

$$Z_{0ps} \rightarrow \infty$$

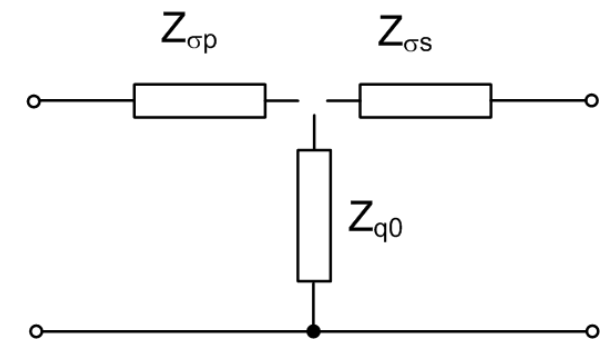
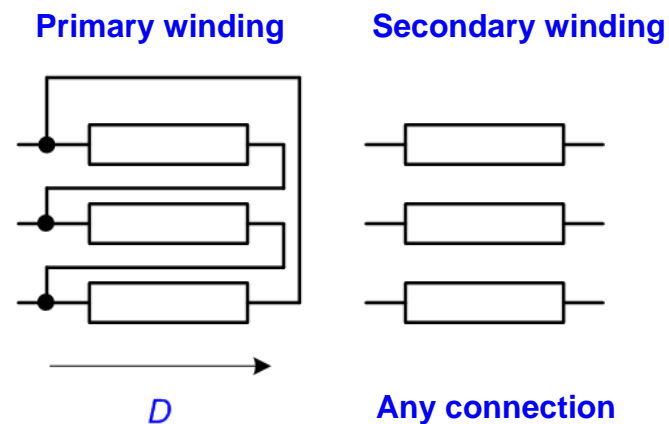

c) **YN / D**

Currents in the primary winding i_0 induce currents i_0' in the secondary winding to achieve magnetic balance.

Currents i_0' in the secondary winding are short-closed and do not flow further into the grid.

$$\hat{Z}_{0p0} = \hat{Z}_{\sigma p} + \hat{Z}_{q0}$$

$$\hat{Z}_0 = \frac{\hat{u}_0}{\hat{i}_0} = \hat{Z}_{\sigma p} + \frac{\hat{Z}_{\sigma s} \cdot \hat{Z}_{q0}}{\hat{Z}_{\sigma s} + \hat{Z}_{q0}}$$

shell

$$\hat{Z}_{q0} = \hat{y}_q^{-1} \gg \hat{Z}_{\sigma s} \rightarrow \hat{Z}_0 \approx \hat{Z}_{\sigma ps} = \hat{Z}_{1k}$$

3-core

$$|\hat{Z}_{q0}| < |\hat{y}_q^{-1}| \rightarrow |\hat{Z}_0| \approx (0,7 \div 0,9) |\hat{Z}_{\sigma ps}|$$

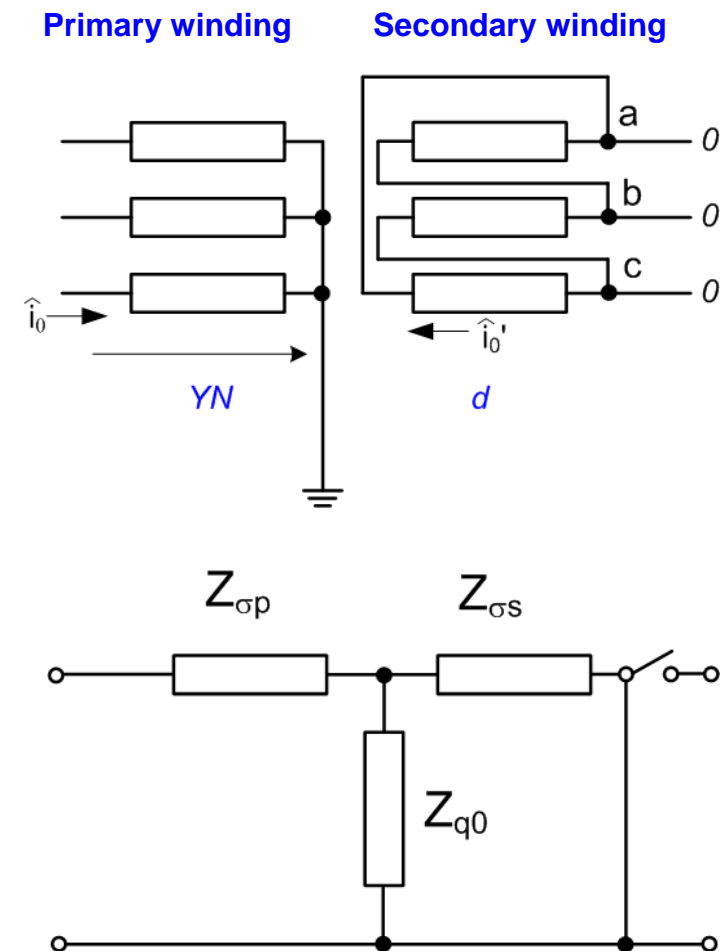

d) YN / Y

Zero sequence current can't flow through the secondary winding.
Current i_0 corresponds to the magnetization current.

$$Z_{0ps} \rightarrow \infty$$

$$\hat{Z}_0 = \hat{Z}_{0p0} = \hat{Z}_{\sigma p} + \hat{Z}_{q0}$$

shell

$$\hat{Z}_{q0} = \hat{y}_q^{-1} \rightarrow Z_0 \rightarrow \infty$$

3-core

$$|\hat{Z}_{q0}| < |\hat{y}_q^{-1}| \rightarrow |\hat{Z}_0| \approx (0,3 \div 1)$$

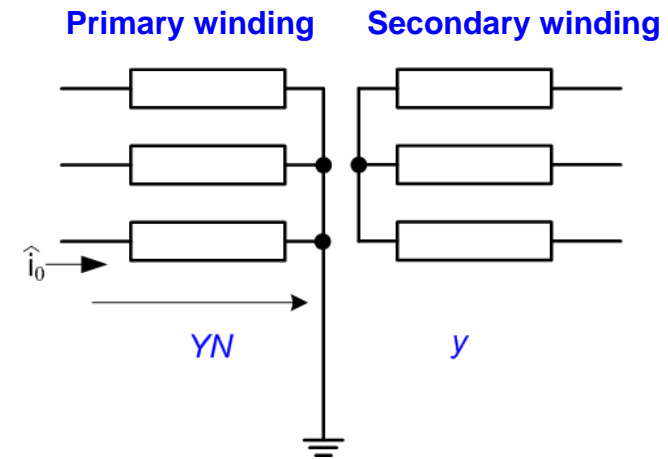

e)

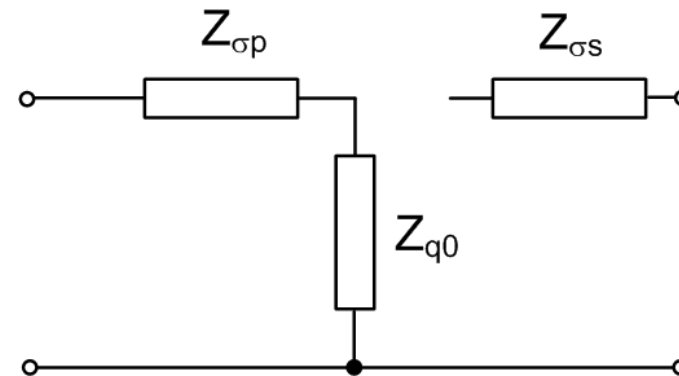

e) **YN / YN**

If element with YN or ZN behind TRF → points a-b are connected → as the positive sequence.

If element with Y, Z or D behind TRF → a-b are disconnected → as YN / Y.

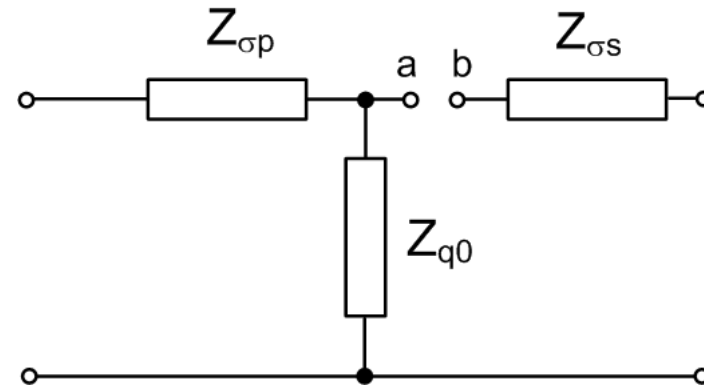
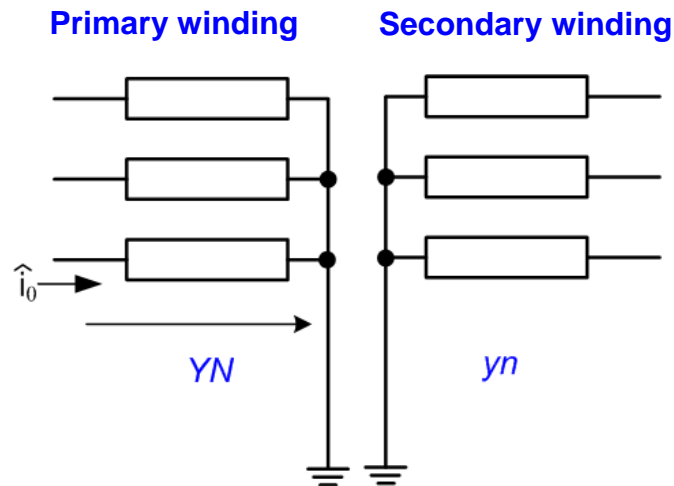

f) ZN / any connection

Currents i_0 induce mag. balance on the core themselves \rightarrow only leakages between the halves of the windings.

$$Z_{0ps} \rightarrow \infty$$

$$\hat{Z}_0 = \hat{Z}_{0p0} \approx (0,1 \div 0,3) \hat{Z}_{\sigma ps}$$

$$r_0 = r_p$$

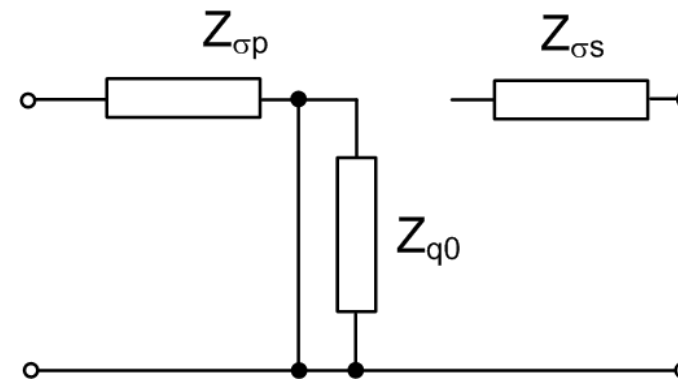
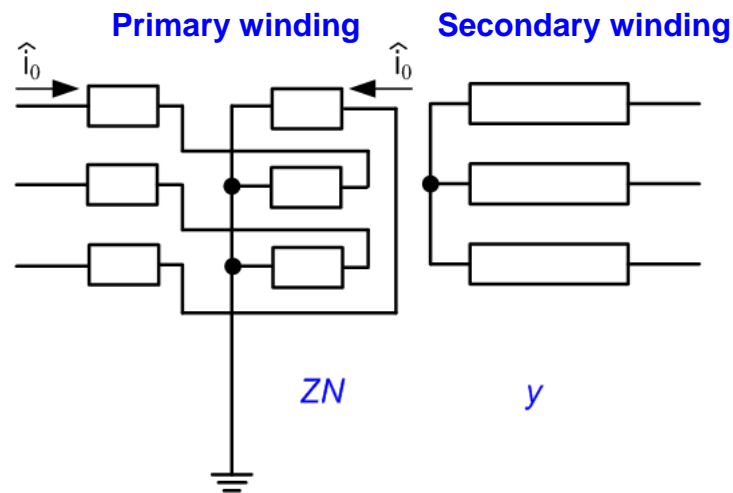

g) impedance in the neutral point

Current flowing through the neutral point is $3i_0$.

Voltage drop: $\Delta \hat{u}_{uz} = \hat{Z}_u \cdot 3\hat{i}_0 = 3\hat{Z}_u \cdot \hat{i}_0$

h) three-winding TRF

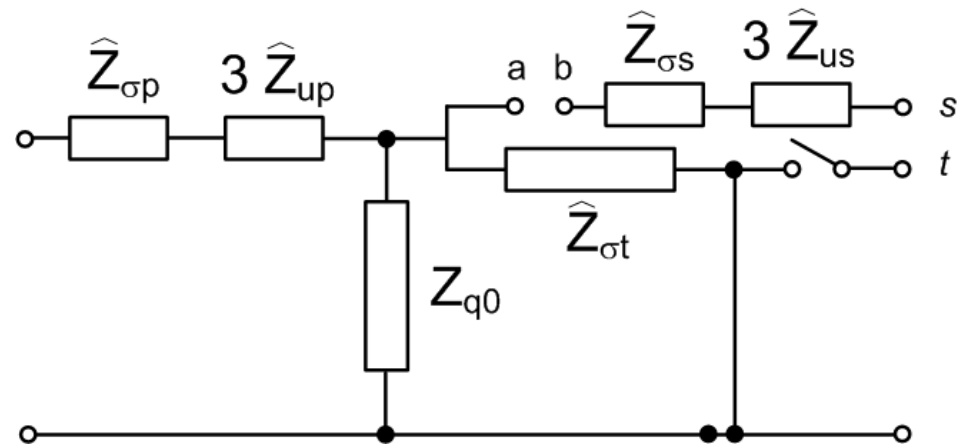
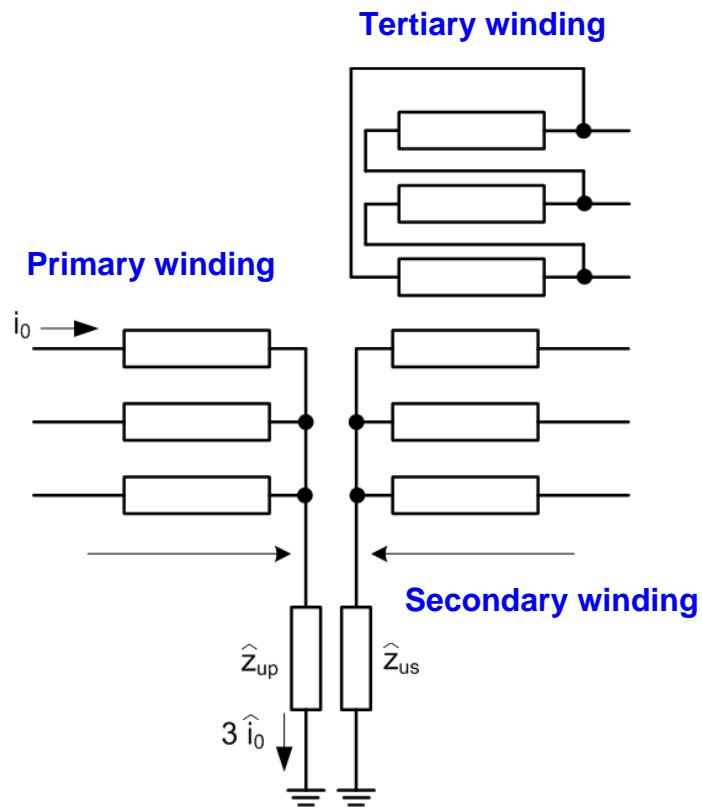

System equivalent

Impedance (positive sequence) is given by the nominal voltage and short-circuit current (power).

Three-phase (symmetrical) short-circuit: S_k'' (MVA), I_k'' (kA)

$$S_k'' = \sqrt{3} U_n I_k''$$

$$Z_s = \frac{U_n^2}{S_k''} = \frac{U_n}{\sqrt{3} \cdot I_k''}$$

CR:	400 kV	$S_k'' \approx (6000 \div 30000) \text{ MVA}$	$I_k'' \approx (9 \div 45) \text{ kA}$
	220 kV	$S_k'' \approx (2000 \div 12000) \text{ MVA}$	$I_k'' \approx (2 \div 30) \text{ kA}$
	110 kV	$S_k'' \approx (100x \div 3000) \text{ MVA}$	$I_k'' \approx (x \div 15) \text{ kA}$
	22 kV	$S_k'' \approx 10x \text{ MVA}$	$I_k'' \approx x \text{ kA}$
	0,4 kV	$S_k'' \approx 100x \text{ kVA}$	$I_k'' \approx x \text{ kA}$