

Power System Transients

Overvoltage

- Maximum supply voltage U_m – maximum effective value of line voltage that can occur at any time or place under normal operating conditions

Rated voltage (kV)	6	10	22	35	110	220	400	750
Maximum supply voltage (kV)	7,2	12	25	38,5	123	245	420	787

- Overvoltage – any line or phase voltage that exceeds the amplitude of maximum supply voltage ($u > \sqrt{2}U_m$)

Types of Overvoltage

- Divided by
 - Magnitude
 - Duration
 - Cause of occurrence
- The magnitude of an overvoltage is expressed by an overvoltage coefficient that is determined from either relative or absolute values:

$$k_f = \frac{u_{fm}}{\frac{\sqrt{2}U}{\sqrt{3}}}$$

Where U is the maximum supply voltage and u_{fm} is the maximum line-to-ground overvoltage

- By duration
 - Permanent overvoltage – power frequency, constant effective value
 - Temporary overvoltage – power frequency, 0.03 s - 3600 s
 - Transient overvoltage (slow, fast, very fast) – duration of units of ms or shorter, damped oscillating or impulse characteristic
 - Combined overvoltage – a combination of two types of overvoltage

Types of Overvoltage

- By cause of occurrence
 - Internal overvoltage (operating) – its magnitude can be defined as a multiple of rated voltage of the relevant network
 - External overvoltage (lightning) – its magnitude is independent on rated voltage of the relevant network

Internal overvoltage

Faults

(ground fault, short-circuit)

Switching operations

(switching of capacitive and inductive currents, semiconductor devices)

Electrical resonance

(resonance and ferroresonance)

Switching operations on power lines

(Load switching, automatic reclosing)

External overvoltage

Direct lightning strike to the network

Overvoltage induced by a near lightning strike

Lightning-caused overvoltage in buildings

Switching off of Short-Circuit AC

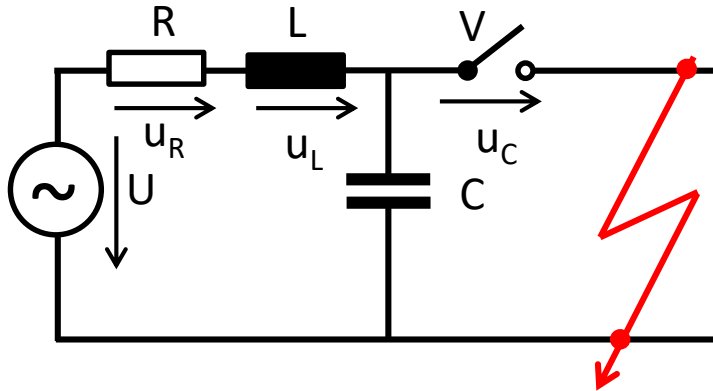

$$Ri + L \frac{di}{dt} + u_C = U \cos(\omega t)$$

$$i = C \frac{du_C}{dt}$$

$$RC \frac{du_C}{dt} + LC \frac{d^2 u_C}{dt^2} + u_C = U \cos(\omega t)$$

$$\gamma = \frac{R}{L} \quad \omega_0^2 = \frac{1}{LC} \quad \frac{d^2 u_C}{dt^2} + \gamma \frac{du_C}{dt} + \omega^2 u_C = U \cos(\omega t)$$

We assume that the transient event is periodic and damped (weak damping), i.e. $\gamma < 2\omega_0$; therefore the general solution is:

$$u_{C0} = e^{-\frac{\gamma}{2}t} \sin(\omega_f t + \varphi), \text{ where } \omega_f = \sqrt{\omega_0^2 - \frac{\gamma^2}{4}}$$

And the particular solution is:

$$u_{Cp} = B \cos(\omega t + \psi)$$

Switching off of Short-Circuit AC

The resulting voltage u_c can be then expressed as:

$$u_c = u_{c0} + u_{cp} = e^{-\frac{\gamma}{2}t} \sin(\omega_f t + \varphi) + B \cos(\omega t + \psi)$$

By putting $u_c = u_{cp}$ into the differential equation for u_c , we receive the following equation:

$$-B\omega^2 \cos(\omega t + \psi) - B\gamma\omega \sin(\omega t + \psi) + B\omega_0^2 \cos(\omega t + \psi) = \frac{U}{LC} \cos(\omega t)$$

This expression can be visualized by a phasor diagram in the following manner:

$$\frac{U}{LC} = \omega_0^2 U$$

We can see from the figure that B a ψ are:

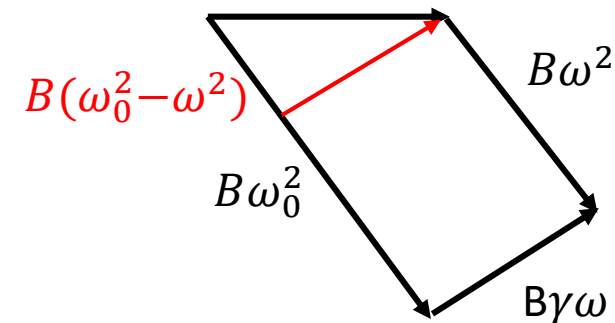

$$B = \frac{U\omega_0^2}{\sqrt{(\omega_0^2 - \omega^2)^2 + \gamma^2\omega^2}}$$

$$\psi = \arctg\left(\frac{\gamma\omega}{\omega_0^2 - \omega^2}\right)$$

Switching off of Short-Circuit AC

During the switching off of short-circuit current, we assume that the voltage u_c is zero in the beginning of the process, i.e.:

$$u_c(0) = 0$$

By employing the previous equation as an initial condition, we can determine the only remaining unknown parameter φ .

The resulting voltage trend of u_c (on switch contacts)

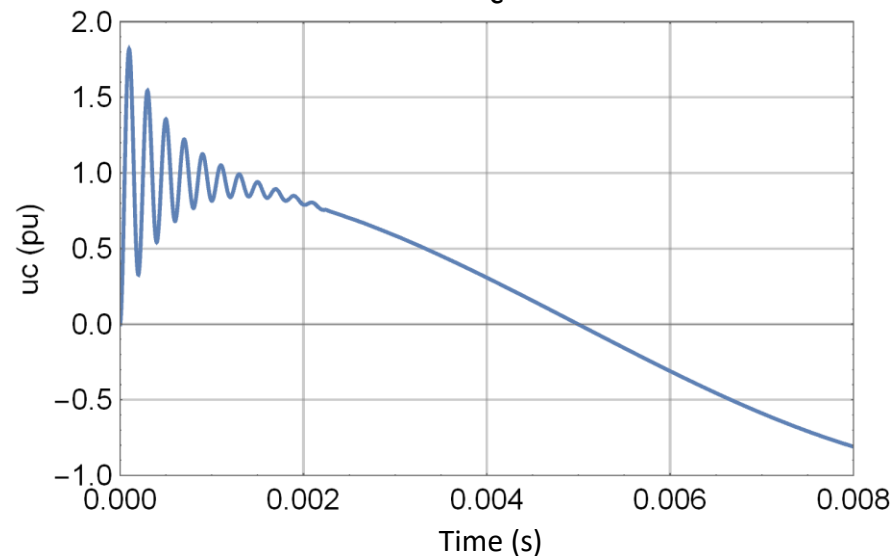

Switching off of Small Inductive Currents

- Inductive currents are relatively small when compared to the rated current (e.g. no-load current of transformer, no-load current of a squirrel-cage rotor engine, reactor or Peterson coil current)
- The unstable character of an electric arc inside a switch creates oscillations with erratic amplitudes
- The current should be switched off when its instantaneous value reaches zero.
- The overvoltage factor can reach values of over 2.5.

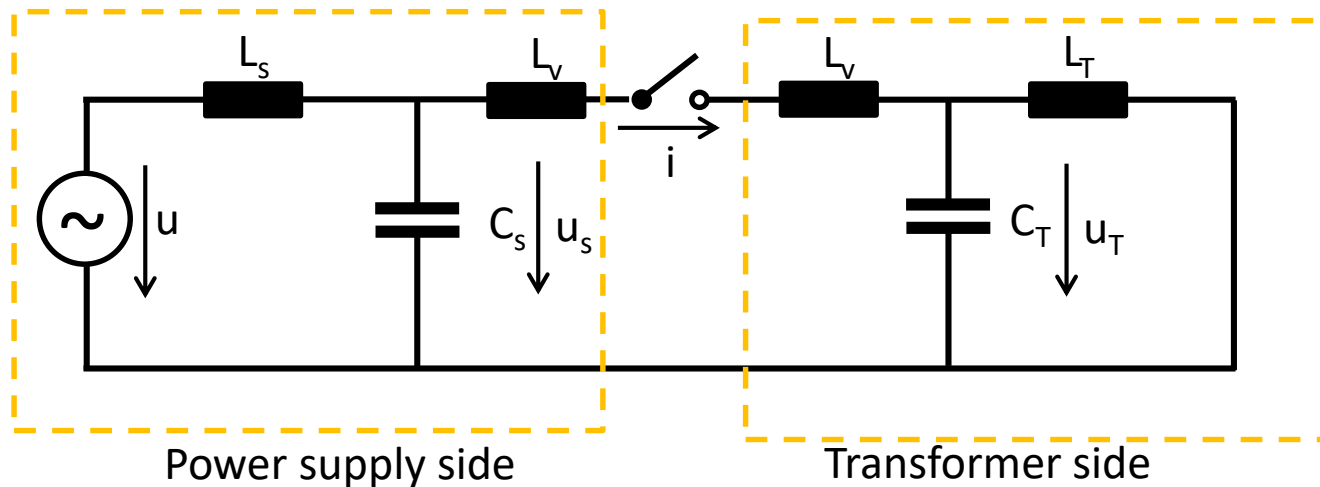

Switching off of Small Inductive Currents

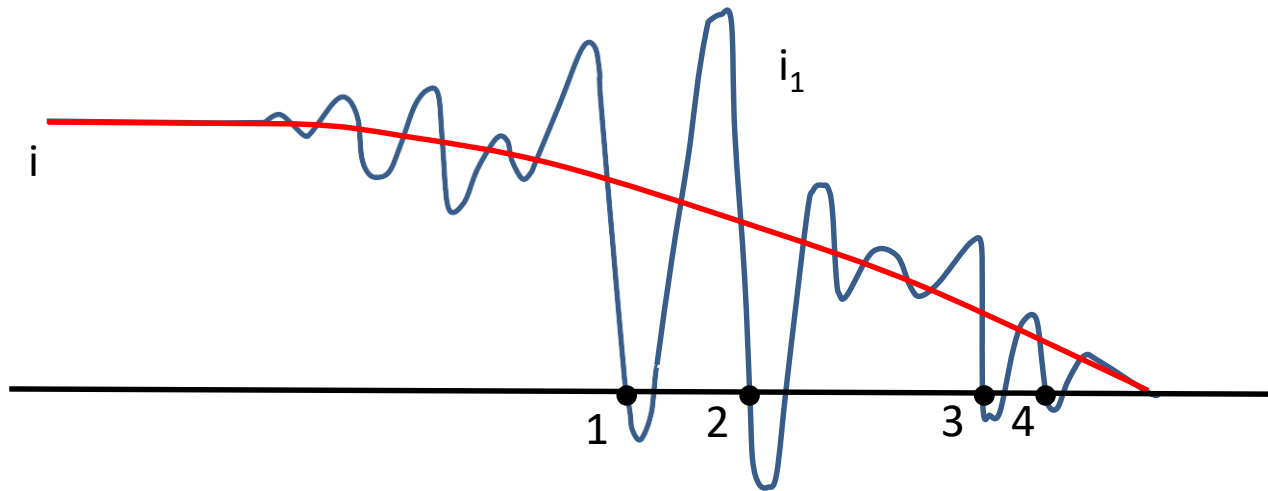

- The transient events caused by unstable electric arc create oscillations that are superposed on power frequency. Therefore, the resulting current reaches zero value already in times 1-4 (see figure).
- If the transient recovery voltage between the switch contacts rises faster than the dielectric strength of the space between both contacts, the circuit reconnects and needs to be switched off again.

Switching off of Small Inductive Currents

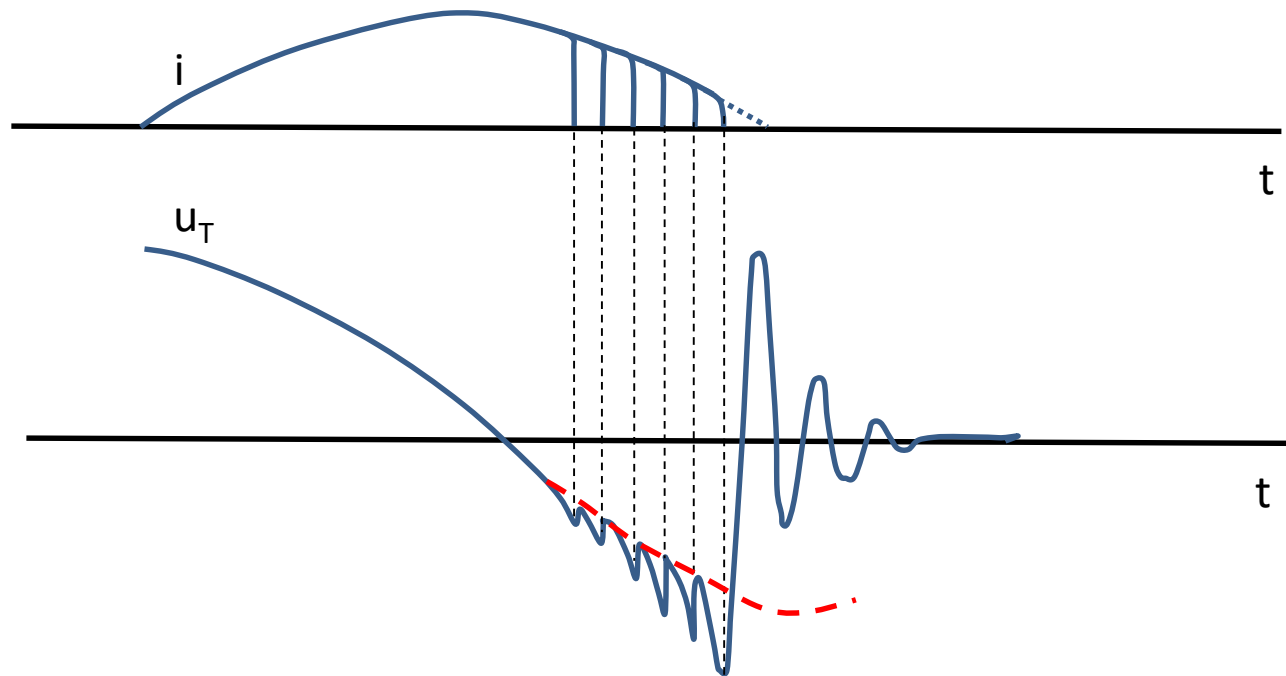

- The voltage between both contacts rises (drops) sharply whilst the distance between switch contacts increases insufficiently. This causes re-ignition of the arc after the first switch operation.
- Repetitive re-ignition creates saw tooth voltage on the transformer side (u_T) of the circuit, as seen in the figure.

Switching of Capacitive Currents

- Overvoltage is caused by switching on and off of capacitive currents (primarily switching of capacitor batteries that serve as reactive power compensators)
- The connection of uncharged capacitor battery C_B to the power source (u, L, C) by switching of switch S forms a current, which is limited only by inductance L of the power source in the first few moments.
- Since C_B is much larger than C , voltage and current oscillations emerge. Frequency of these oscillations is given by parameters L and C_B .
- Overvoltage during the switching reaches a maximum value equal to the double of the source's amplitude.

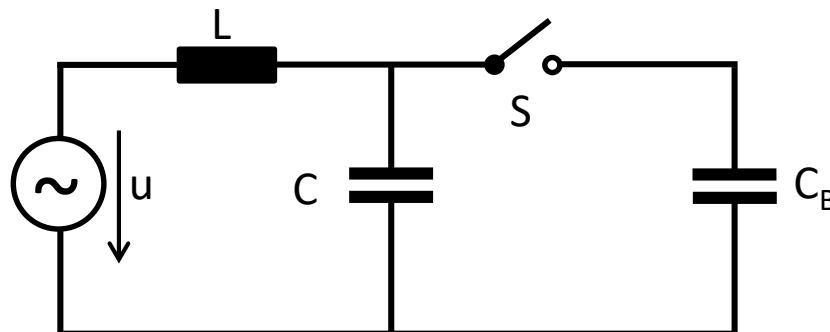

Switching off of Capacitive Currents

- With S switched on, the voltage on C_B is higher than on the power source.
- When the switch is disconnected, the current ceases to flow when it passes zero value. Subsequently, a voltage difference emerges between the switch contacts.
- The voltage of the source part of the circuit drops down to the network voltage via a transient event. The voltage of the battery part of the circuit remains constant.
- The voltage difference between contacts increases and an electric arc ignites at time 2. Voltage on C_B changes to u_C via a transient. The maximum overvoltage during the event is equal to the triple of u_C

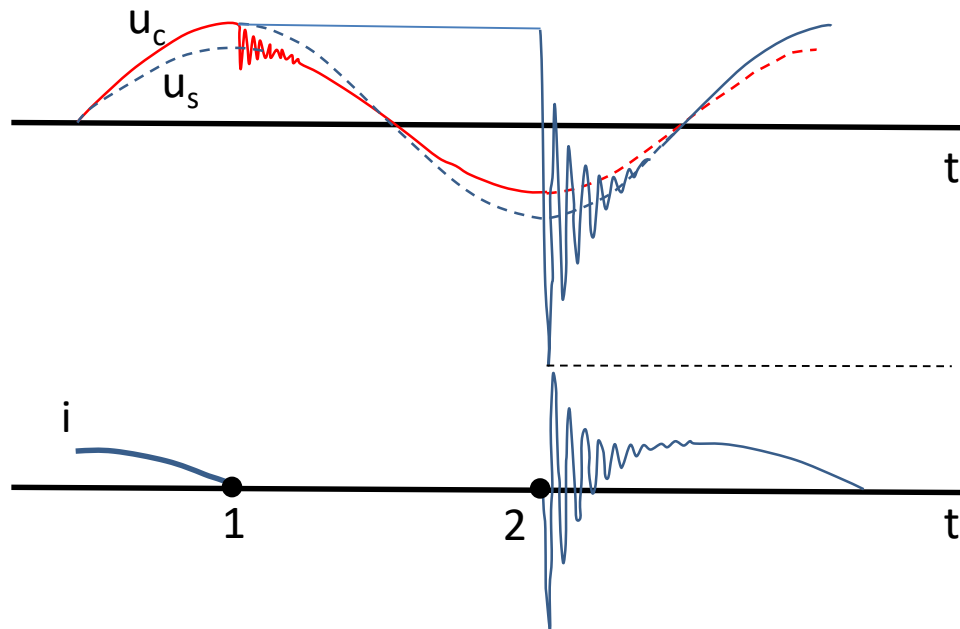

Travelling Waves

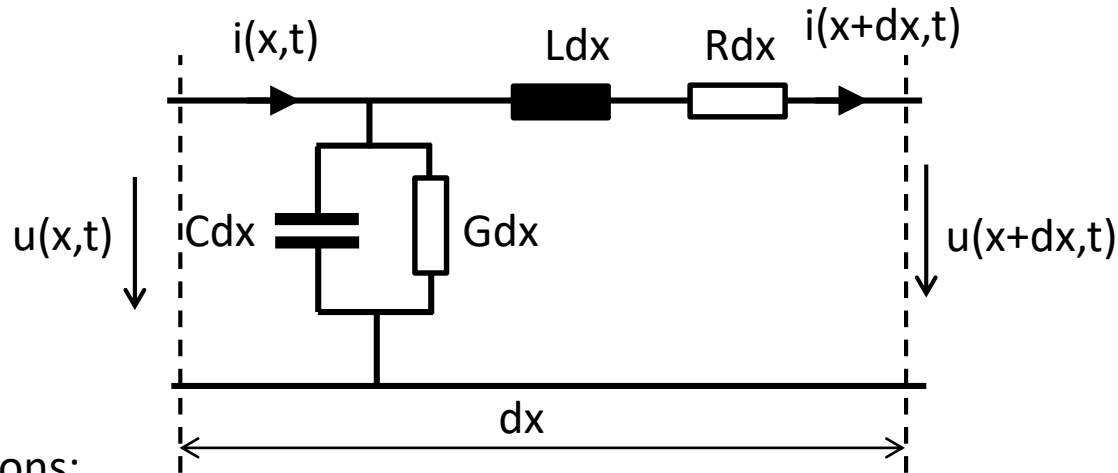

Circuit equations:

$$-u(x, t) + Rdx i(x + dx, t) + Ldx \frac{\partial i(x + dx, t)}{\partial t} + u(x + dx, t) = 0$$

$$i(x, t) - Gdx u(x, t) - Cdx \frac{\partial u(x, t)}{\partial t} - i(x + dx, t) = 0$$

$$\frac{u(x + dx, t) - u(x, t)}{dx} = -Ri(x + dx, t) - L \frac{\partial i}{\partial t}$$

$$\frac{\partial u}{\partial x} = -Ri - L \frac{\partial i}{\partial t}$$

$$\frac{i(x + dx, t) - i(x, t)}{dx} = -Gu(x, t) - C \frac{\partial u(x, t)}{\partial t}$$

$$\frac{\partial i}{\partial x} = -Gu - C \frac{\partial u}{\partial t}$$

Travelling Waves

By current/voltage elimination and if the lossless line is assumed ($R \rightarrow 0$ a $G \rightarrow 0$) we can get the final wave equations in the form:

$$\frac{\partial^2 u}{\partial t^2} = \frac{1}{LC} \frac{\partial^2 u}{\partial x^2}$$

$$\frac{\partial^2 i}{\partial t^2} = \frac{1}{LC} \frac{\partial^2 i}{\partial x^2}$$

D'Alembert's solution is any function with argument $(x \pm vt)$, where $v = \frac{1}{\sqrt{LC}}$ is the velocity of wave propagation.

The solution for current wave:

$$i(x, t) = f_1(x - vt) + f_2(x + vt)$$

After substitution to voltage eq. : $\frac{\partial u}{\partial x} = Lv \frac{\partial}{\partial t} [f_1(x - vt) - f_2(x + vt)]$

$$u(x, t) = Lv [f_1(x - vt) - f_2(x + vt)]$$

$$u(x, t) = \sqrt{\frac{L}{C}} [f_1(x - vt) - f_2(x + vt)]$$

Travelling Waves

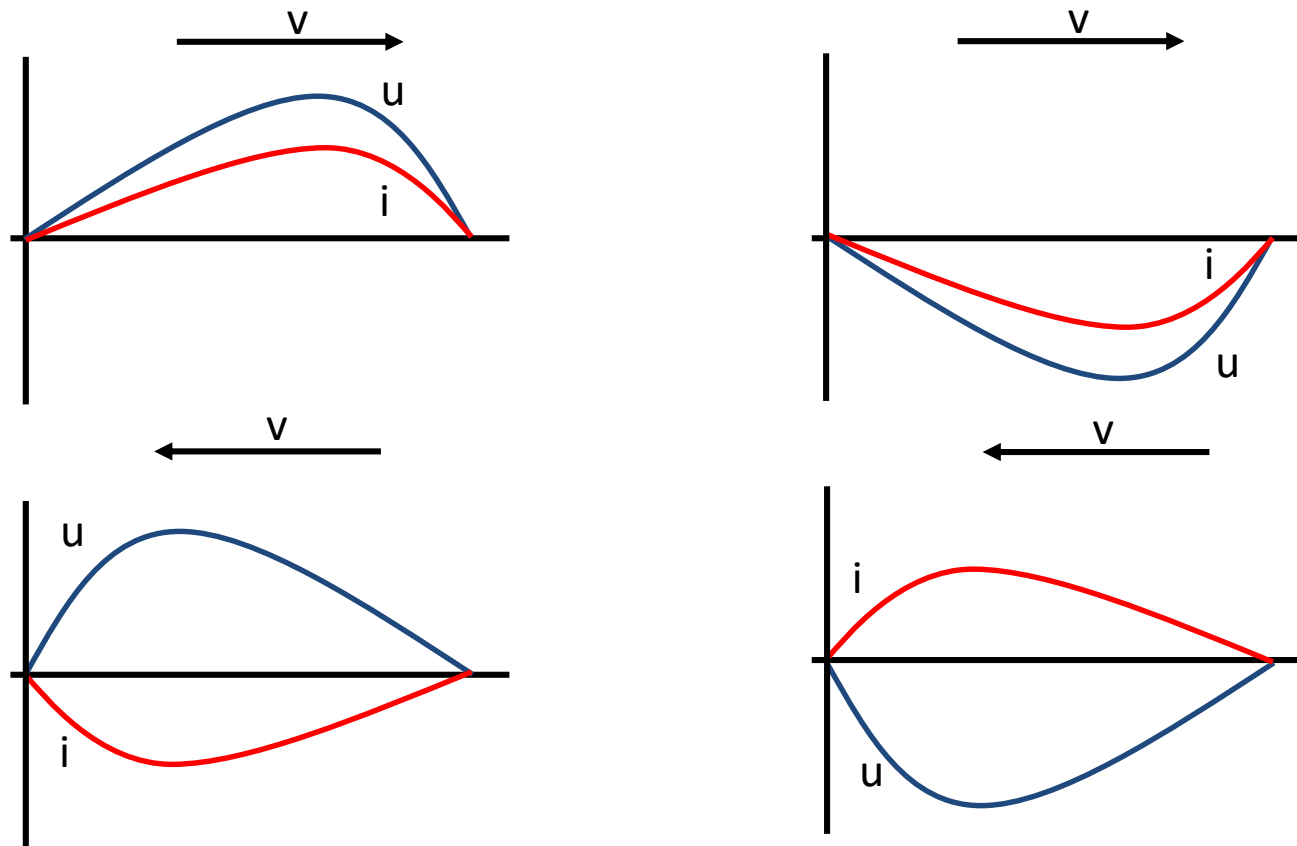

Voltage backward wave is in the phase with the forward wave, current backward wave is in opposite phase to forward wave.

Boundary influence to travelling waves

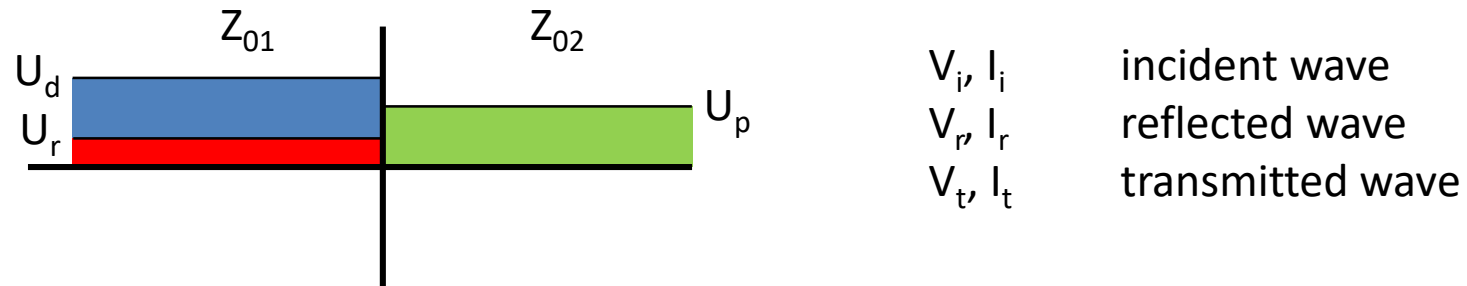

Currents can be expressed as :

$$I_i = \frac{V_i}{Z_{01}} \quad I_r = -\frac{V_r}{Z_{01}} \quad I_t = \frac{V_t}{Z_{02}}$$

Voltage and current equation for border:

$$V_t = V_i + V_r \quad I_t = I_i + I_r$$

Boundary influence to travelling waves

Voltage reflection coefficient $\rho_V = \frac{V_r}{V_i}$:

$$\frac{V_i}{Z_{01}} - \frac{V_r}{Z_{01}} = \frac{V_i}{Z_{02}} + \frac{V_r}{Z_{02}}$$

$$\frac{V_r}{V_i} = \frac{\frac{Z_{02} - Z_{01}}{Z_{01}Z_{02}}}{\frac{Z_{01} + Z_{02}}{Z_{01}Z_{02}}} = \frac{Z_{02} - Z_{01}}{Z_{01} + Z_{02}}$$

Similarly we can get current reflection coefficient:

$$\rho_I = \frac{Z_{01} - Z_{02}}{Z_{01} + Z_{02}}$$

and voltage and current transmission coefficients:

$$\tau_V = \frac{2Z_{02}}{Z_{01} + Z_{02}} \quad \tau_I = \frac{2Z_{01}}{Z_{01} + Z_{02}}$$

Effect of line terminations

Short-circuit line:

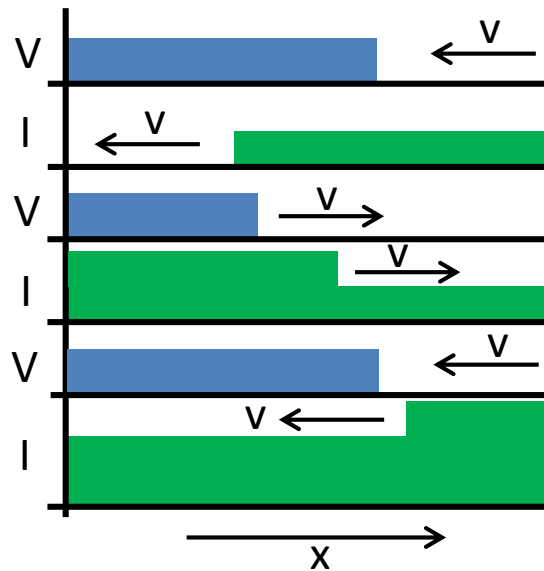
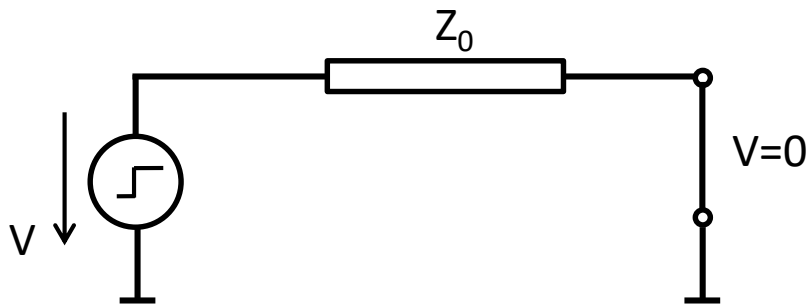

Open-circuit line:

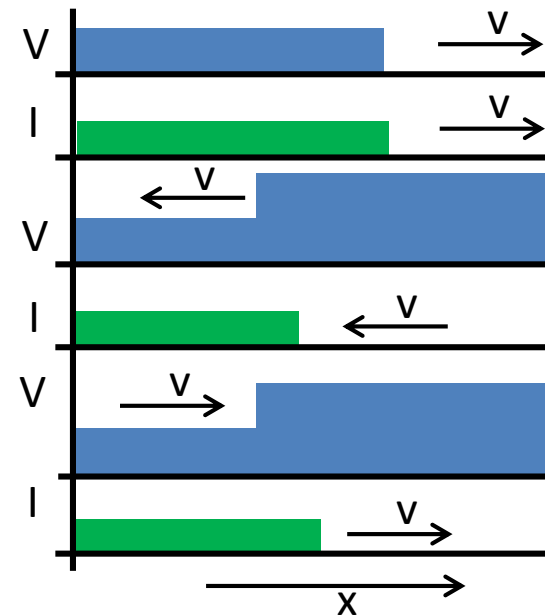
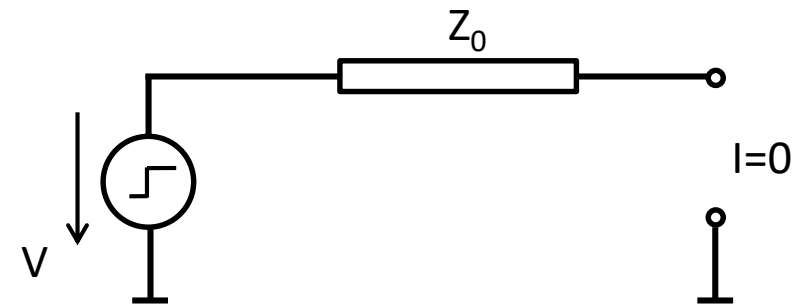

Effects of line terminations

Line termination in inductance:

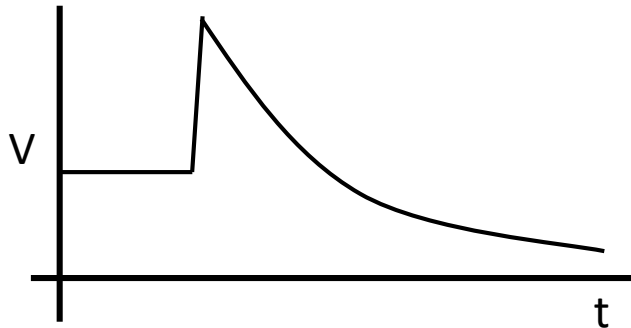
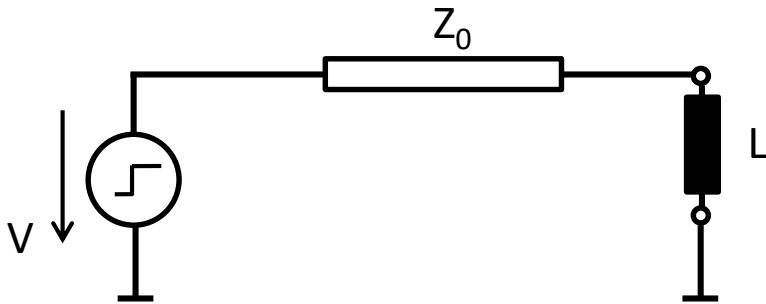

Line termination in capacitance:

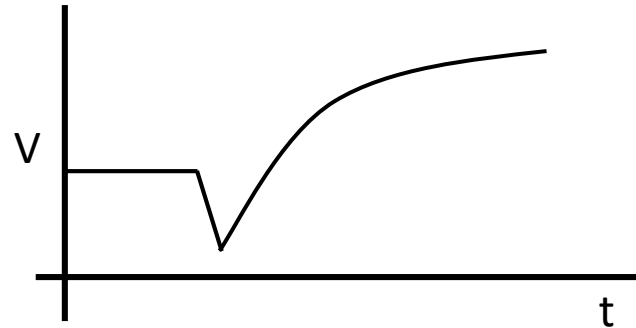
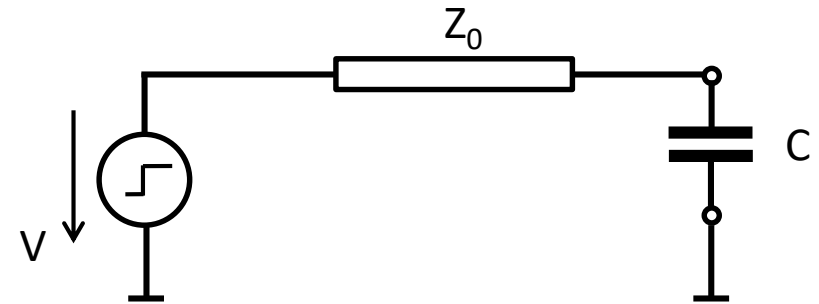

Lightning discharge

- Cause overvoltage in electric power systems
- Lightning discharge origin is determined by lightning cloud (cumulonimbus) existence, which is a consequence of intensive vertical air flow



<http://www.jacksonsweather.com>

Charge distribution in cloud

- Inside the cloud the charge separation occurs – many theories of charge separation mechanism exists, the whole process is still not fully understood
- Upper part of cloud consists of ice crystals with positive charge while lower part of cloud consists of negatively charged water droplets
- Negative charge in the lower part of clouds and positive charge in its upper part or induced positive charge on the ground can be neutralized by lightning discharge, so we can recognize:
 - Lightning discharge between centers of negative and positive charge inside the clouds
 - Lightning discharge between clouds and Earth's surface

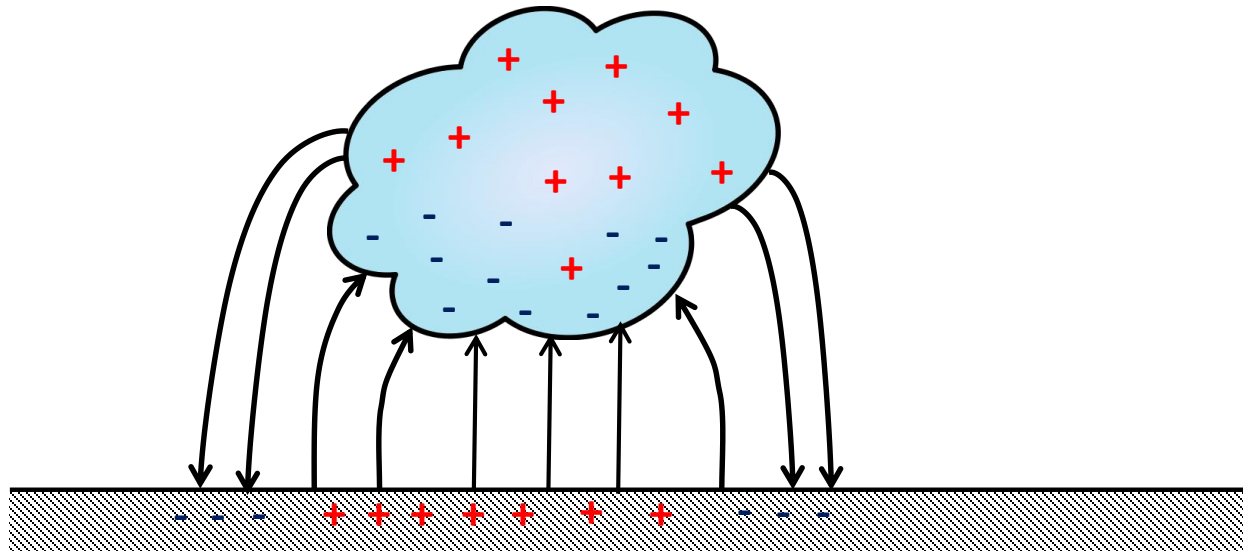

Lightning discharge propagation

- Discharge propagation from cloud to ground is going in steps (approx. 20 m) which are elongated towards Earth's surface
- This discharge is called stepped leader and the head of the leader is moving with the velocity in order of 10^5 m/s to ground, approaching the ground the upward discharge starts to move
- By final connection of both discharges the highly conductive path is created and potential difference cause current impulse and return stroke
- Return stroke (the main visible event) follows the path of both previous discharges (with the speed approx. 10^7 - 10^8 m/s), flashing with a lasting approx. 0.1 s

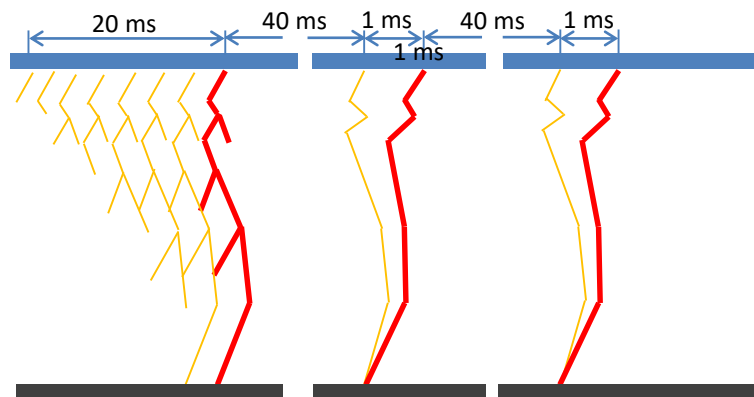

Current of Lightning Discharge

- Lightning current waveform is important for an assesment of lightning effects to electric power systems
- Parameters of current waveforms are statistical values given on the base of observations
- Negative first partial discharge has higher amplitude than subsequent partial discharges
- Positive lightning has higher amplitude and lower steepness
- Total time of lightning duration is usually hundrets of miliseconds

Peaks of currents (kA)	Cumulative frequency		
	95%	50%	5%
Negative first partial discharge	14	30	80
Negative subsequent partial discharge	4,6	12	30
Positive lightning	4,6	35	250

Overvoltages caused by lightning discharge

- Overvoltages can be caused by:
 - Voltage drop across conductor with lightning current
 - Electromagnetic field which arises as consequence of lightning discharge
- Overvoltages on overhead lines and in buildings can be classified as:
 - Direct lightning stroke to overhead lines
 - Induced by lightning discharge
 - Caused by lightning discharge in buildings

Direct stroke to overhead line

- Injected current impulse propagates to both sides of overhead line -> current and voltage travelling waves
- Voltage and current waves are reflected in locations where the change of surge impedance is present
- If the overhead line ground wire is struck the reflections occur in the place of joints with towers and in the place of grounding of towers
- The most dangerous overvoltages arise at direct stroke of lightning to phase conductor of line, assuming the peak current of lightning discharge $I_m = 30 \text{ kA}$ and line surge impedance $Z_v = 300 \text{ } \Omega$ and the peak value of overvoltage is:

$$V_m = \frac{Z_v}{2} I_m = \frac{300}{2} 30 \cdot 10^3 = 4,5 \text{ MV}$$

Overvoltages induced to line

- Lightning stroke cause rapid change of electromagnetic field and origin of induced voltages
- Dangerous overvoltage for insulation system can arise if the lightning strokes somewhere in the distance up to 5 km from overhead line

